

THE
ULTIMATE
DEVELOPMENT
EVERYTHING

PAGE ONE

Starduster

JANUARY 1979

MAGAZINE

DEDICATED TO THE ACTIVE HOMEBUILDER



STOLP STARDUSTER CORP.

PAGE ONE

AN OPEN LETTER TO:



FEDERAL AVIATION ADMINISTRATION
Office of the Chief Counsel
ATTENTION: RULES DOCKET AGC-24
800 Independence Avenue, S.W.
Washington, D.C. 20591

Regarding: NPRM Docket Number 18605 Notice Number 78-19

Gentlemen:

In the last few years there have been a number of mid-air collisions involving airliners that were under positive control. The Grand Canyon Crash, involving two airliners, the Tenerife Island tragedy involving two airliners, and the San Diego tragedy involving an airliner and a Cessna come quickly to mind. In all these tragedies the aircraft involved were under positive control.

Since the system failed in these instances, why now the proposal to vastly extend the system and rob general aviation of vast slices of airspace?

In my business, I have frequent contact with airline pilots. They all are of the opinion that the airliner involved in the San Diego tragedy was at fault. Playing the tapes involved just before the crash confirm this.

I have been told by a number of airline pilots that they are so busy during landings and takeoffs, because of ATC required paperwork, that they do very little peering out of the cockpit. One pilot said he keeps a sharp lookout, but qualified that by saying the glare shield is so high that he can't scan his flight path when he is descending. I asked couldn't he adjust his seat upwards for better vision. He said yes, but then it would be out of adjustment for landing and require readjusting just when he would be busiest.

I suggest a reapportionment of air space as per the EAA and AOPA plans. I also suggest operating rules changes to the effect that at least one member of airline flight crews be designated the PRIMARY job of scanning the skies during takeoffs and landings. I also suggest that at least one crew member be required to adjust his seat so that he can see the flight path before him during landings.

Mid air collisions are tragedies. However, let us work reasonably and rationally to eliminate them. In spite of media distortion and mass hysteria, let us not throw out the baby with the bathwater.

Respectfully,

JIM OSBORNE *Jim Osborne*
PRESIDENT
STOLP STARDUSTER CORP.

JANUARY 1979

THE STARDUSTER MAGAZINE- DEDICATED TO THE PROPOSITION THAT THE ULTIMATE IN SPORT AIRCRAFT WAS REACHED WITH THE DESIGN AND DEVELOPMENT OF THE OPEN COCKPIT, TAIL DRAGGING BIPLANE--AND THAT EVERYTHING ELSE HAS BEEN DOWNHILL----EVER SINCE.

TABLE OF CONTENTS

PAGE ONE, EDITORIAL-----1

HOW TO BUILD A WOODEN, FABRIC COVERED, WING-----3

PRODUCT INFORMATION-----10

THE "A PICTURE IS WORTH A THOUSAND WORDS" DEPARTMENT----11

STATEMENT OF LIABILITY OF "AMATEUR-BUILT" AIRCRAFT-----13

ELECTRICAL SYSTEM DIAGRAM-----14

PIREPS PAGE-----17

CLASSIFIED ADS-----30

This magazine is not copyrighted, except as noted. Permission is hereby given to reproduce any part of it, for the benefit of Sport Aviation, providing credit is given to the publisher, STOLP STARDUSTER CORPORATION.

The STARDUSTER MAGAZINE is a quarterly publication, published in January, April, July, and October of each year. Subscription rate is \$6.00 per year. Published by STOLP STARDUSTER CORPORATION, 4301 Twining, Riverside, California, 92509.

Our front cover picture this month shows the beautiful and brand new STARDUSTER TOO of Mr. ORISON CLEVELAND, of Melbourne Beach, Fla.

On our back cover is a gorgeous photo of ELDON PAULSON and wife PEARL, flying in thier nice STARDUSTER TOO. This is the same airplane in which the Paulsons had a forced landing in the Mojave desert a year or so ago. A perfect landing was made in hilly country on a winding road. The only damage was a scratched wingtip.

OUR TWO INFLATION FIGHTING POLICIES--

1. We give 3-5 lbs of short length tubing free, with each substantial tubing order. suitable for welding practice. Sorry. No size selections.

2. A 10 % discount will be given to walkin customers who select thier own tubing from our short lengths rack, providing no cutting is done. If cutting is provided, regular prices will prevail.

HOW TO BUILD A WOODEN, FABRIC COVERED, WING (All rights reserved.)

A wooden, fabric covered, wing is generally a flexible structure. In biplanes, such a wing is braced by struts and wires, and the degree of twist in such a wing, if any, is determined by the rigging of these struts and wires.

The first requirement for building such a wing panel is to have adequate working space. If you don't have one, build yourself a plywood work bench big enough to accommodate your largest wing panel. Level the work bench with a carpenter's level. It is nice to build the wing in a level plane, since our biplanes do not have any washin, or washout. However, a great deal of precision is not necessary, as the wings ARE torsionally flexible.

Make six bench standoffs from scrap wood, as per sketch at right. These standoffs are screwed to the bench and the spars are clamped to them. Three to a spar. Sometimes a spar has a gentle curve in it, when viewed from above. By using three clamps per spar, any such curvature can be taken out. After the spar is finished the drag truss will keep it straight. Install standoffs with convenient spacing, so that they do not interfere with ribs or drag truss tubes. If standoffs are clamped against a spar plate allowance must be made for the thickness of the spar plate when positioning the standoff.

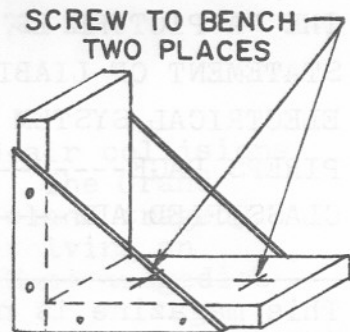

CLAMPS TO BE
GLUED & NAILED
TOGETHER

shown below is a work bench with the standoffs properly located for clamping to spars.

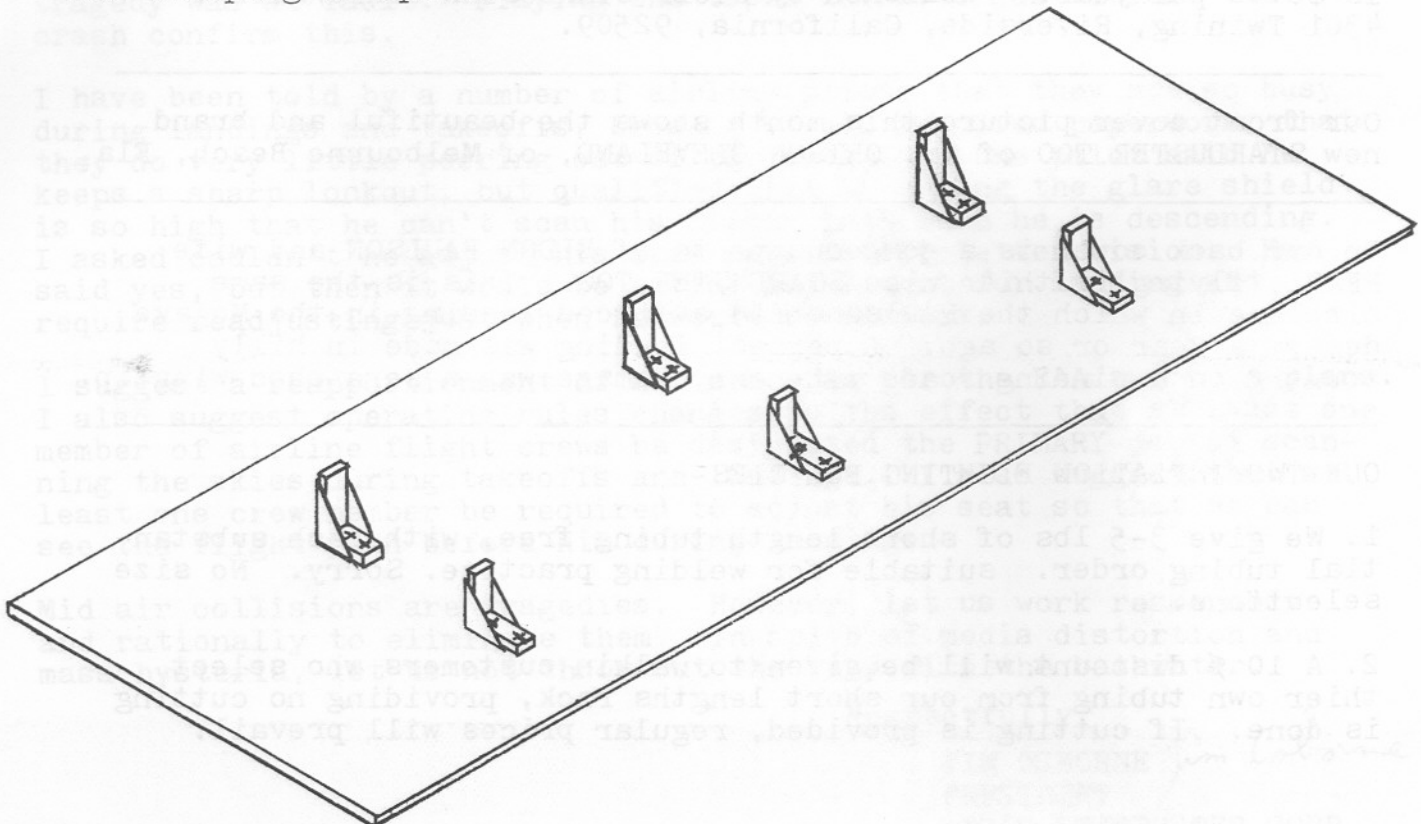

The work bench should be properly lighted and heated. It should also be a dry area, not subject to rain leakage or basement damp.

Now that we have a proper work area, we can begin to build our wing.

WING FITTINGS- Except for the aileron hinges and fittings, most wing fittings are flat metal, either steel or aluminum. If you are working from one of our wing kits the flat fittings will be roughly sheared to size. You must round the corners, file and smooth the edges, and drill the holes. Our fitting drawings are full size. Make copies of the fittings, (Zerex or traced) and use the copies as templates. Glue the copy onto a rough fitting with contact cement. File or grind the first fitting to match the glued on drawing outline. Drill all holes that go thru the spar 1/16" undersize. If it is a 1/4" hole, drill 3/16". DO NOT DRILL ANY WING ATTACH HOLES IN THE BUTT FITTINGS.

After your first fitting is made, stack it with other like fittings. Drill holes thru the stack, and bolt the unfinished fittings to your finished example. File, sand or grind, by hand or machine, your stack of fittings until they are quite close in contour to your #1 fitting. Finish contour the stack by hand, individually, using a file and fine emery cloth. Break all edges. Finish sand lengthwise along the edges. Scratches across the edges are verboten. Remove any scratches on the surface of the fittings with fine emery cloth, or a hard rubber electric eraser. Or use a rotary polisher and jewelers rouge.

Your finished product should be a stack of identical fittings, with all drilled holes identical, and of an identical shape.

Using a precision reamer, now ream all drilled holes to their final diameter.

Repeating the above procedure, make all the flat fittings for all your wings.

On your butt fittings it is a good idea to leave the front spar fittings not only with the attach holes blank, but also with the attach tab oversize. This allows more latitude in locating the attach hole on wing installation without the risk of coming up with short edge distance.

Your top wing, butt fittings require a 6 degree bend in them, if you are building one of our airplanes. This bend can be made by clamping the fitting in a bench vise, with the tab projecting out. Lay a metal bar against the tab and bend by hitting the bar with a hammer. Make a template with a 6 degree bend line and use it to insure that your bend is accurate.

See 6 degree bend below. You may use it as template.

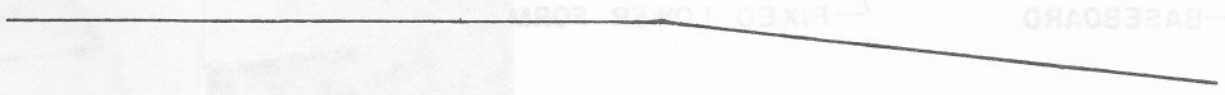

ittings made from extruded aluminum are a little more complicated to make. Our Acroduster Too has aileron hinge fittings made from Extruded Tee stock. This is perhaps the most difficult fitting to make. Start by making one matching pair of hinges, complete with holes. (Drill holes undersize, and ream to final diameter.) Hinge holes in this first set of hinges should be match drilled and reamed. Now, separate this matched set of hinge fittings. Use the right hand hinge as a mating part to make the other seven left hand hinges. Likewise, use the original left hand hinge to make the other seven right hand hinges.

Use a similar procedure to make aileron horns and other non-flat fittings.

After all wing fittings are made, clean with acetone, MEK, paint thinner, toluene, or some such solvent. Clean them again. Then spray paint with zinc chromate. Set fittings aside until needed.

RIBS- Wooden ribs can be any one of three types. Starduster Ribs are routed out of a piece of aircraft plywood. They are finished when you receive them. Skybolt ribs are made of spruce strips which are assembled in a jig to form a truss. Acroduster ribs are made from thin webs (plywood) cap strips, (spruce), and plywood stiffeners on center web, nose web and tail web.

A jig is necessary to assemble truss type and thin web/capstrip type ribs. For acroduster ribs, make the jig fit the longest rib. Using wedges in the tail piece, shorter ribs can be easily accommodated in the long jig. See jig drawings below.

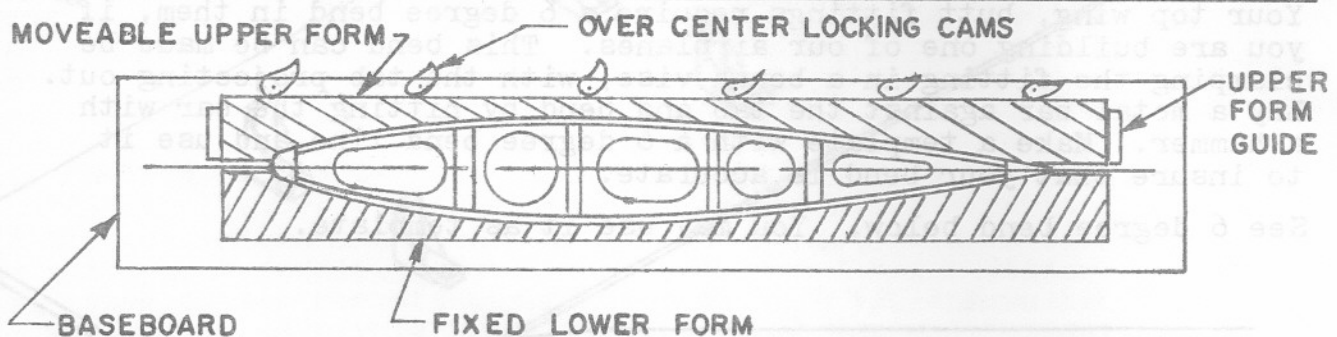
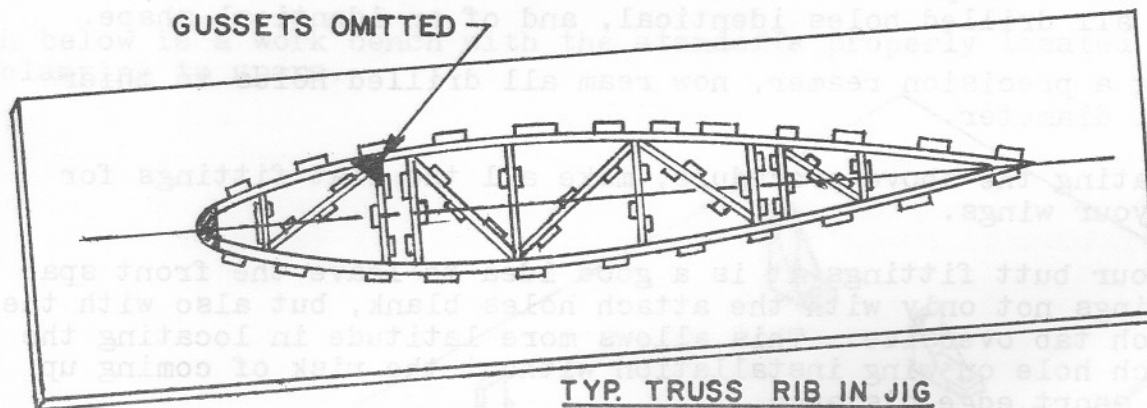

TYP. JIG FOR THIN WEB/CAPSTRIP TYPE RIBS

Since the number of jigs is usually limited, rib-making can be a slow process. It is usually most feasible to make one or two ribs a day, interspersing the process with work on fittings and spar assemblies.

After all the ribs are made, they should be precision contoured.

They should all be ganged together on the spars, or simulated spars, and the contours checked against each other. Also, leading edge strip should be checked for fit at the same time contour is checked. See pictures below.



Picture on the left shows ribs all ganged together on spar ends. Bottom picture shows leading edge inserted for checking.

Ribs may be sanded to get a smooth set of matching contours. However, no more than $1/32$ " should be sanded off any capstrip. If some ribs are below contour too far to be made even by a light sanding they should be replaced, or built up by glueing on thin strips of wood and then sanding down to contour.

If the ribs are all made in one jig there is little likelihood of there being any significant variation.

On ribs routed from solid plywood, like Starduster Too ribs, more can be sanded off in order to get a matching contour. But there is little likelihood of there being much mismatch.

When sanding check carefully for reverse curvature, or waviness. This is an absolute no-no. If you find it you goofed somewhere. Start over.

Because of the aluminum covering, the leading edges of the ribs is by far the most crucial when it comes to matching contours. The leading edge is also by far the most critical aerodynamically.

A perfect contour match is not nearly so important aft of the front spar.

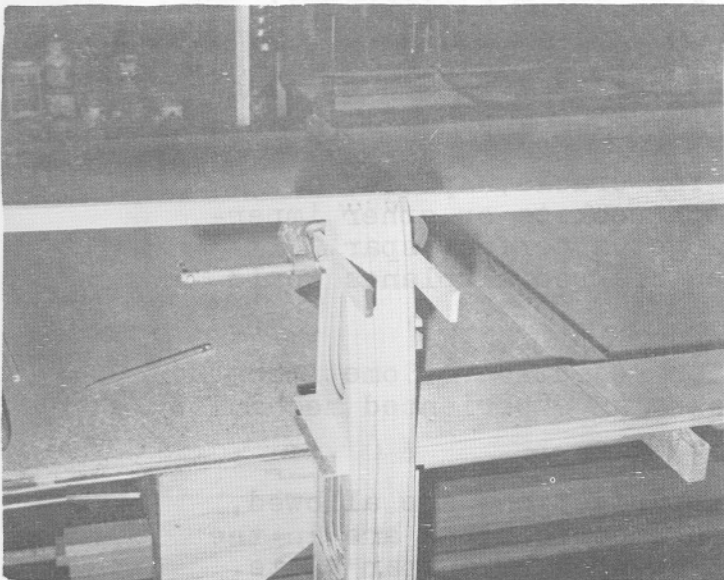

GLUE-Some of the most violent partiansanship in building airplanes is between people who like different kinds of glue. The way it usually develops is a new builder asks a more experienced friend what kind of glue he should use. The friend recommends the glue he has used and had good luck with. New builder uses it and also has good luck. Now his mind is made up. His glue is best; the ONLY one to use. And from then on, he recommends it to anyone else.

As a matter of fact, any glue approved for aircraft construction will give excellent results, if properly used. The old standby, weldwood plastic resin is time proven, cheap, and easy to use. It is noncritical in mixing, and nontoxic. Overflow can easily be wiped away, and it does not discolor the wood. It does require clamping pressure of 125 psi,(approximate), and it does require a temperature of 70 degrees or higher. The clamping requirement is met by spacing cement coated aircraft nails about one per inch in every direction thru the mating parts.

Since the sole purpose of the nails is to provide alignment and glueing pressure, they can be removed after the glue dries. The easiest way to do this is to drive the nails thru nailing strips and then thru the mating parts. The nailing strips can be narrow strips of thin plywood. After glue dries pull nailing strip and nails away from structure.

There are various catylst type glues available which do a good job. Resorcinol and Hughes are two popular ones. They are more expensive, and more critical in thier mixing. Clamping pressure is not so critical, nor is heat. Catylst glues work well at lower temperatures. They tend to discolor the wood when squeezed out between joints. There may also be a problem of allergy or rash sensitiveness in users. And cleanup is more difficult, with spills likely to damage floors or furniture.

One of the best and easiest to use catylst glues is Aerolite. Its advantage is in the way it is mixed. The glue is mixed with water to form a thin paste. The the glue is spread on one mating part and the catylst on the other. Clamping pressure should be applied to aerolite for about 2-1/2 hours at a temperature of 60 degrees or higher. At lower temperatures, longer cure times are required. Pot life of the glue and catylst, when kept separate, is about three months. Because the glue and catylst are kept separate, the cleanup of spills is easy.

SPAR ASSEMBLIES- This is one of the most critical phases of wing building.

First of all, INSPECT the spar. Check for cracks, splits, or warps or waviness. Note any knots, pitch pockets or other imperfections. It is unlikely that you will get a perfect spar. If perfection was required, very few wooden sparred airplanes would be built.

Cracks and splits are generally cause for rejection. Sometimes they can be repaired, but it usually takes an experienced mechanic to know when and how.

Small knots, pitch pockets, and other imperfections are allowed, within reason. It is better if any such imperfections are in the middle of a spar, best is they are also covered by a spar plate.

Inspecting the spar from the top, a slight curve or bend is no cause for concern. The drag truss will straighten it out. However, if the spar curves up or down, in the vertical plane, it is unacceptable.

CEL CEL BATTERIES- Newly moist warranty procedure. According to the manufacturer's instructions, you should store them in a cool, dry place. Naturally, after receiving your spars, and before you use them, you have used care and judgement in storing them. You did not store them flat, supported only at the ends, of course. This is a sure way to get a curvature. And you stored them in a dry place, where they would not be subject to water damage, or extreme changes in humidity. And, of course, they weren't stored for several years in an attic, or the rafters of a garage, where they would be subject to extreme summer heat and winter cold. That is a good way to develop cracks and splits.

Wood defects which are permissible in spars are as follows:

1. Cross grain. Spiral or diagonal grain, provided such grain does not deviate from centerline of spar more than 1" in 15" of travel. Check all four faces to determine divergence.
2. Wavy, curly, or interlocked grain. Acceptable, if local irregularities do not cause excessive runout.
3. Sound hard knots of 3/8" or less are acceptable, provided they are not along the spar edge. They should be in the center third of the beam, and not closer than 20" to another 3/8" knot. Smaller knots can be proportionately closer together.
4. Pin Knot Clusters. Small clusters acceptable, providing they have only a minor effect on grain direction.
5. Pitch pockets. Acceptable in center third of beam provided they are at least 14" apart, and not larger than 1-1/2" long by 1/8" wide by 1/8" deep.
6. Mineral streaks. Acceptable providing careful inspection reveals no decay.

Wood defects which are unacceptable are as follows:

1. All otherwise acceptable defects which exceed limitations given above.
2. Spike knots. These are knots running completely thru the depth of a spar, perpendicular to the annual rings.
3. Decay. (Usually accompanied by mineral streaks.)
4. Dry cracks or splits.

Compression failure. Overstressed in compression due to natural forces during growth of tree, felling tree, or extremely rough handling of wood. Buckled fibers appear as streaks on surface of wood, at right angles to grain. Appearance varies

from obvious failures to fine hairline cracks that require close inspection to detect.

After we have inspected our spars, and found them acceptable, we proceed as follows. Cut the spars to exact length and taper the ends as required. Position and glue on all spar plates, using either clamps or nails to provide proper glueing pressure and alignment.

Now comes a critical operation. Properly position on one side of your spar only, all fittings that go on that spar. Double check the location. Mark around them lightly with a soft lead pencil. Remove all fittings except one. Put the spar and fitting on a drill press which is level and has the bit in an accurate vertical plane. Level the spar. Support it as needed and check its levelness with a carpenters level. When this is done drill ONE hole thru the spar, using your in-place fitting as a guide. Slip a short bolt thru the fitting and into the spar. Then drill the rest of the holes needed for that fitting, inserting a bolt after each hole. Remove fitting and bolts, and repeat process with each remaining fitting. If you have been accurate in your work, all fittings for that spar are ready to bolt on.

One exception to the above. DO NOT DRILL MOUNTING HOLES FOR AILERON HINGE HANGERS ON REAR SPARS AT THIS TIME. However, drill all the other spar holes, including holes for drag truss bolts.

Now, wherever a fitting goes on a spar, put two coats of varnish on that spar. Do not varnish anywhere else. In particular, do not varnish anywhere that you are later going to put glue.

We now have our fittings, our spar assemblies, and our rib assemblies. All the hard work has been done. Now comes the fun part.

Assemble the spars and ribs of a wing panel loosely together. Locate and clamp the spars on the bench standoffs. Put ribs in their approximate position only. Do not attach ribs to spars.

Now, install drag truss fittings on both spars. This is a permanent installation. Tighten bolts to a snug fit. DO NOT OVERTIGHTEN. If overtightening occurs, the wood will be compressed and weakened.

Using a tape measure, determine the length of each piece of drag truss tubing in that wing panel. Cut tubing to length as accurately as possible. Cut wooden plugs from dowels, and install into ends of drag truss tubing. Dip plug into varnish before installation, so that varnish will seal upon installation and make the inside of the tube airtight.

Make a trial installation of the drag truss tubes. You will have to round the tube ends, as viewed from above, in order to get a good fit and still allow adequate bolt edge distance. When tubes fit properly, drill mounting holes thru fittings and tubes along one spar only. Drill undersize and ream to proper fit. Insert bolt thru fitting and tube.

TO BE CONTINUED IN NEXT ISSUE OF STARDUSTER MAGAZINE-----

PRODUCT INFORMATION

GEL CEL BATTERIES- Newly modified waurunty procedure. According to Globe Union, manufacturers of the Gel Cel Battery, the following procedure is now to be followed for waurunty service.

The customer with a battery problem contacts Stolp Starduster. We issue the customer a debit memorandum and a copy of the purchase invoice, if the customer has lost his invoice copy. Customer returns battery to GLOBE BATTERY DIVISION, GLOBE UNION, INC., 900 KEEFER AVE., MILWAUKEE, WISCONSIN, 53212, DELIVER TO N. E. DOCK 4. Send along with the battery your debit memo and copy of the purchase invoice.

Send STARDUSTER CORP. a copy of your shipping invoice. We will then send you a new battery, either free, or prorated, as the case may be. Do not send battery to us.

Battery guaruntee remains at three months unconditional, or one year prorated.

PARACHUTES- Our line of seat pack and back pack parachuts has expanded and improved. The following options are now available.

1. Low speed non adjustable seat pack. Rated for opening speeds up to 150 MPH. At least one has opened perfectly at 200 MPH. Available with carrying case for \$460.00. Choice of colors.

2. Low speed adjustable seat pack. Good for use where many people will be wearing it. \$480.00 with carrying case.

3. Seat pack, standard category. Unlimited opening speeds. Non adjustable. With carrying case and choice of colors, \$530.00

4. Seat pack, standard category, adjustable. \$550.00

5. Back pack, low speed, nonadjustable. 150 MPH opening speed
Choice of colors. With matching carrying case. \$460.00

6. Back pack, low speed, adjustable. \$480.00

7. Back pack, standard category, non-adjustable. \$530.00

8. Back pack, standard category, adjustable. \$550.00

For a temper foam seat cushion in any of above, add \$19.00.
(They are worth it.)

The trouble with this country is that we need much stricter laws against child abuse. I have taken about all the abuse from my child that I am going to.

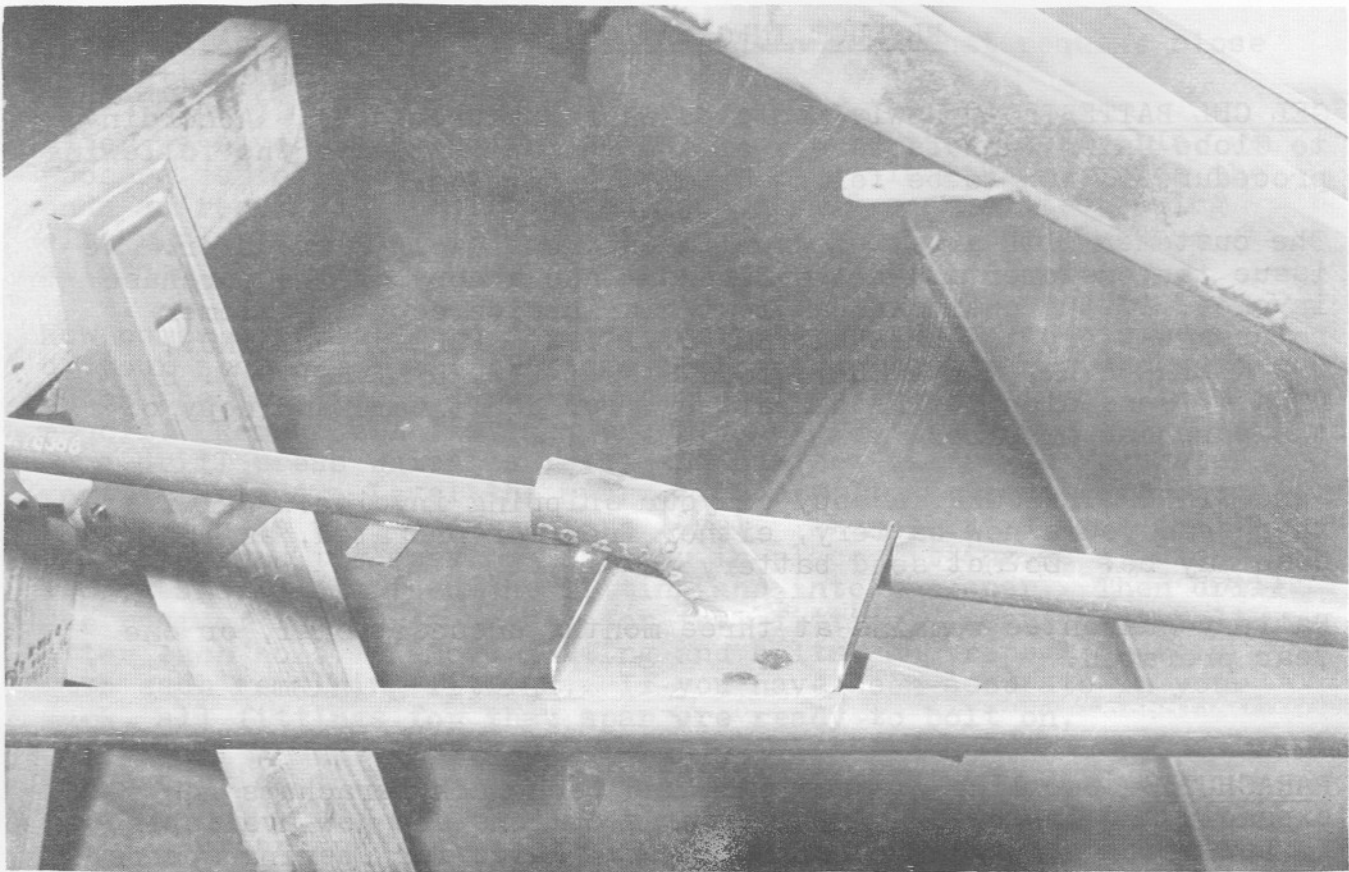

WHENEVER WE BUILD AN AEROBATIC AIRPLANE WE ARE FACED WITH THE PROBLEM OF WHAT TO DO WITH THE OIL WHICH OVERFLOWS WHENEVER WE PULL NEGATIVE "G's". THE MOST COMMON SOLUTION IS TO PIPE IT TO THE REAR OF THE AIRPLANE AND DUMP IT OVERBOARD. THE FITTING ABOVE, IN THE TAIL OF A STARDUSTER TOO SOLVES THE PROBLEM NICELY. PIPE OIL TO FITTING THRU 1" PLASTIC OR ALUMINUM TUBE.

ON THE RIGHT IS A PICTURE OF A MILITARY THROTTLE QUAD INSTALLED IN A STARDUSTER TOO. THIS IS A FRONT COCKPIT INSTALLATION. FRONT AND BACK QUADRANTS ARE CONNECTED BY 1/4 x 3/8 RECTANGULAR TUBE. NOTE THE ELONGATED TABS WITH TWO HOLES. ONE HOLE IS FOR FASTENING TO QUADRANT ARM, AND ONE HOLE IS FOR ATTACHING TO ENGINE CONTROLS.

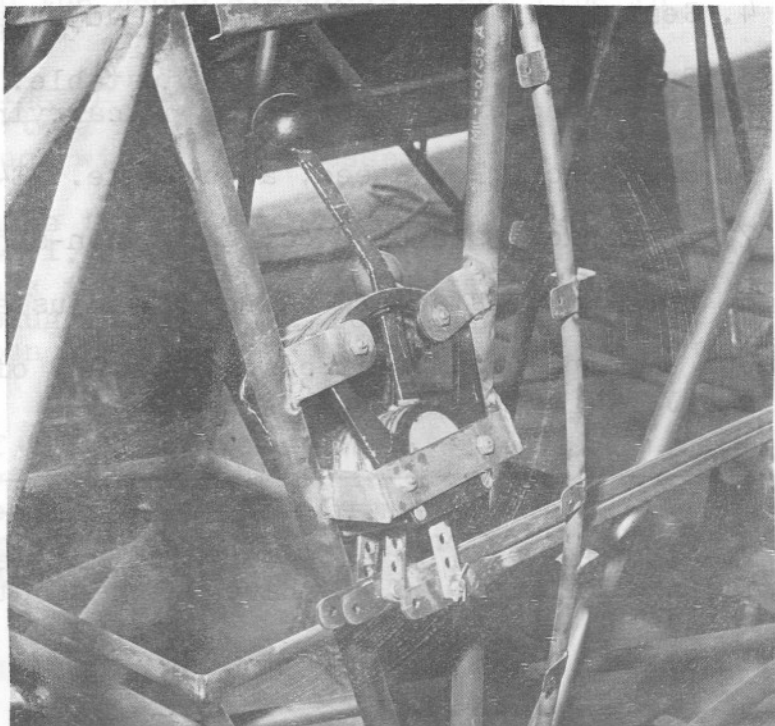

TO BE CONTINUED IN NEXT ISSUE

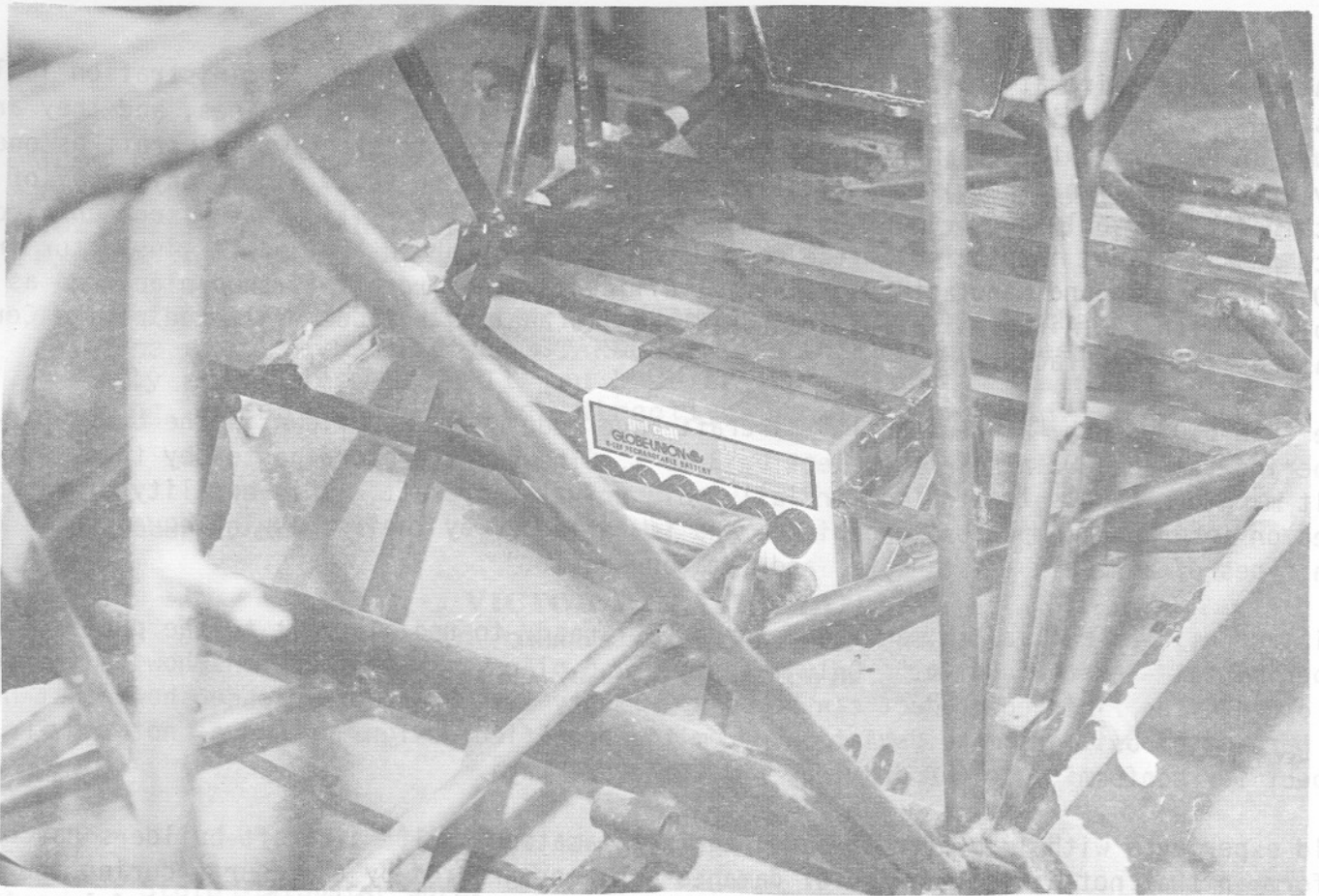

SHOWN ON THIS PAGE IS A GEL CEL BATTERY INSTALLATION ON THE STARDUSTER TOO BELONGING TO HANK HENDERSON, OF SAN MARCOS, CAL. NOTE THE "ON ITS SIDE" MOUNTING OF THE BATTERY. NOTES ALSO THE MODIFIED FUSELAGE STRUCTURE WHICH WILL ALLOW FOR MOUNTING THE NEW STARDUSTER ALUMINUM LANDING GEAR.

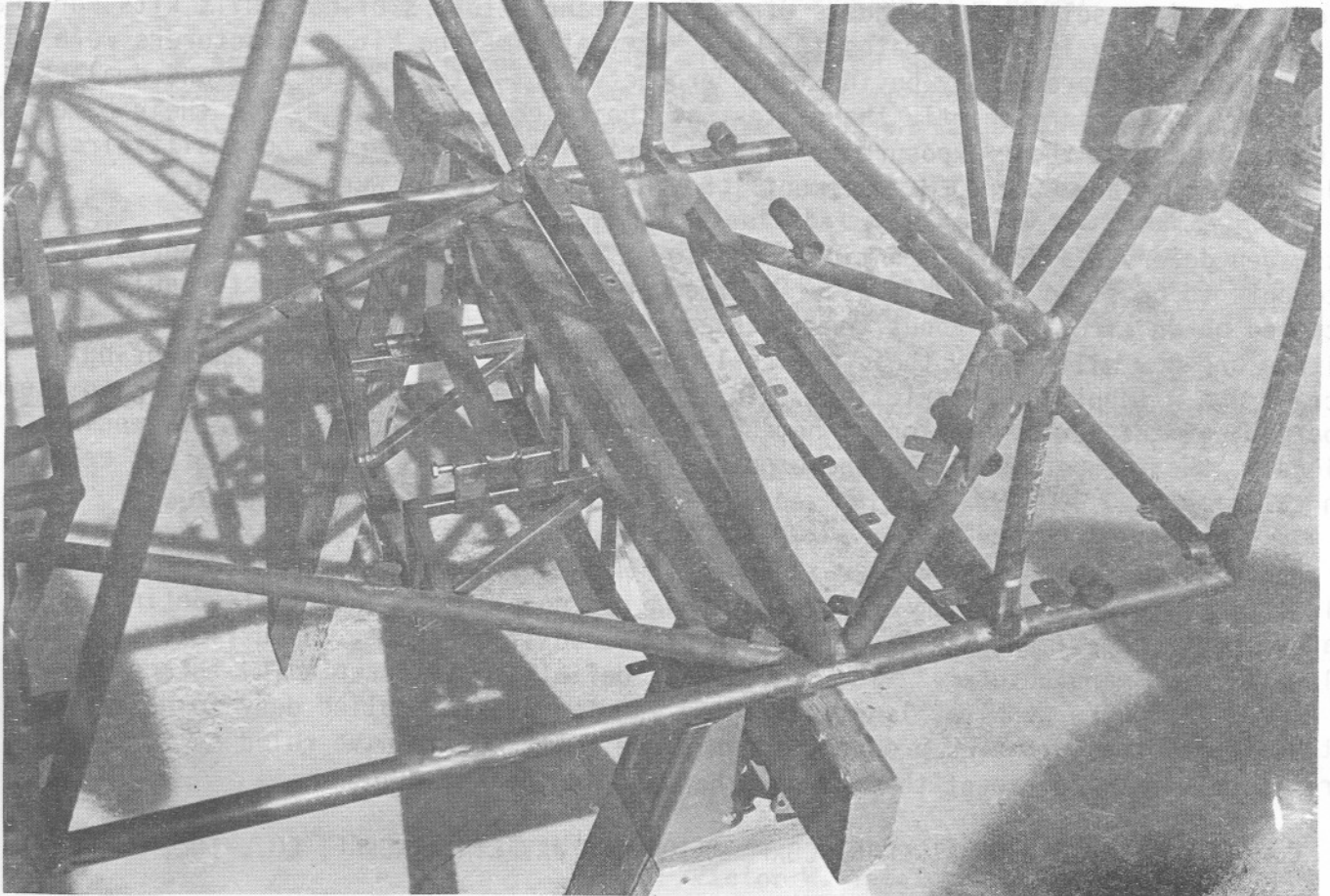

STATEMENT OF LIABILITY OF "AMATEUR-BUILT" AIRCRAFT

"Amateur-built" aircraft category was created by the Federal Aviation Administration in 1953. No standards of quality are prescribed for these "homebuilt" flying machines, and they are issued an "Experimental" Airworthiness Certificate. FAA treats each such aircraft as one and only unique specimen of builder's creative ability and does not hold him to any proof of airworthiness. The only requirement to obtain an Airworthiness Certificate for such an aircraft is to pass a visual inspection of the completed machine by an authorized FAA inspector from EMDO [Engineering and Manufacturing District Office]. The aircraft is then placarded as "not complying with FAA Airworthiness Standards," and its amateur builder is listed on the Certificate as its "manufacturer."

More than 6,000 such "amateur-built" aircraft have been built and flown in the U.S., outnumbering the commercial airline fleet by 3 to 1. The safety record posted by these homebuilt machines equals that of commercially sold private aircraft. This equality of risk is based on insurance companies' experience and is reflected by their charging equal rates for both types of aircraft - "standard" and "amateur-built."

It is against federal law to manufacture and sell ready-to-use aircraft to the public licensed "Experimental - Amateur Built." Only materials and plans with instructions how to fabricate and operate the finished product can be sold. Twenty-five years experience shows that nearly 100 percent of builders make deviations from the specified design. FAA does not require nor inspect for conformity to the drawings [if there are any].

Field experience with liability lawsuits against "amateur-built" aircraft builders has been uniform in that not a single award of damages was ever granted by the courts during the past 25 years. Considering the number of homebuilt airplanes flying, the frequency of lawsuits is very low, and they are usually dismissed by judges before these cases reach juries.

Suppliers of materials and equipment for homebuilt aircraft have never had a claim filed against them. About 15 years ago, Volkswagen, McCulloch, ALCOA and Reynolds Aluminum companies refused to sell their products directly to manufacturers of homebuilt kits for fear of higher liability insurance rates to them. At that time the kit manufacturers were able to circumvent that problem by buying their products from satellite jobbers and dealers. This became unnecessary shortly thereafter, as their legal departments did their homework and determined that their exposure to liability risk was no higher in homebuilt aircraft products than in any other OEM equipment. So, all restrictions were removed.

Volkswagen deserves a special mention, because at one time they demanded "Hold Harmless" statements to be filed by buyers assuring them that their engines and parts would not be installed on an aircraft. About ten years ago, they did a complete about-face in their attitude and now will supply their entire line of engines and parts for "amateur-built" aircraft use without any restrictions. In fact, their cooperation has been so good, some 30 percent of the new generation of homebuilt airplanes and gyrocopters use VW engines. Obviously, their experience with the exposure to liability risk in this area has been more than satisfactory.

The future does not look any dimmer in spite of Washington's obsession with "naderism" and zeal to protect everybody from everything. FAA has no plans to change its definition of the "Amateur-built Experimental" classification of homebuilt aircraft, which lists each individual builder as its "manufacturer." So long as this definition is accepted by the courts as the law of the land, the supplier is protected by manufacturer's implied duty to determine the suitability of the purchased products for his use. The courts have ruled so in the past and there is no reason to expect them to do otherwise in the future.

Just before Christmas we received the letter below from our good friend and Acroduster builder, Vic Tatelman. We wish to thank him for offering to share with us his carefully designed and drawn system for wiring a plane using an external power source for starting.

The original drawing from Mr. Tatelman was redrawn so that it would fit the space available in STARDUSTER Magazine. The design is left exactly as he drew it. If you have any questions pertaining to this drawing, please get in touch directly with Vic Tatelman.

PHONE (305) 247-8439

VICTOR W. TATELMAN

18900 S. W. 232nd Street

Miami (Goulds), Florida 33170

U. S. A.

December 15, 1978

Stolp Starduster Corp.
4301 Twining - Flabob Airport
Riverside, Calif. 92509

Dear Jim and Eric;

RE: Acroduster II - SA750

As you know, I'm not using an alternator on the engine nor an aircraft battery - no lights or other electrical goodies. The engine is started with an external source by means of a standard starting plug in the rear cockpit.

I'm enclosing a diagram of the electrical system I've designed for use with a RADAIR 10 (10 crystal VHF) battery powered radio in conjunction with a remote SIGTRONICS intercom system and an electrically operated oil temperature gauge. You'll also note a diagram of the starting circuit on the drawing.

You certainly may pass the drawing on to anyone else who may want to use this configuration or have them get in touch with me and I'll be glad to send them a print. It works fine and provides a light weight radio for getting into controlled airports. Since I will be flying off a private field, I won't be needing the radio very often, but every once in awhile, it's necessary.

Best regards,

vic
Victor W. Tatelman

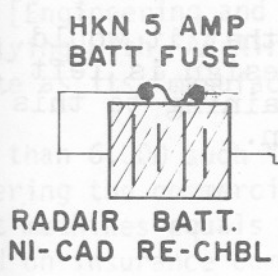

POWER BUS

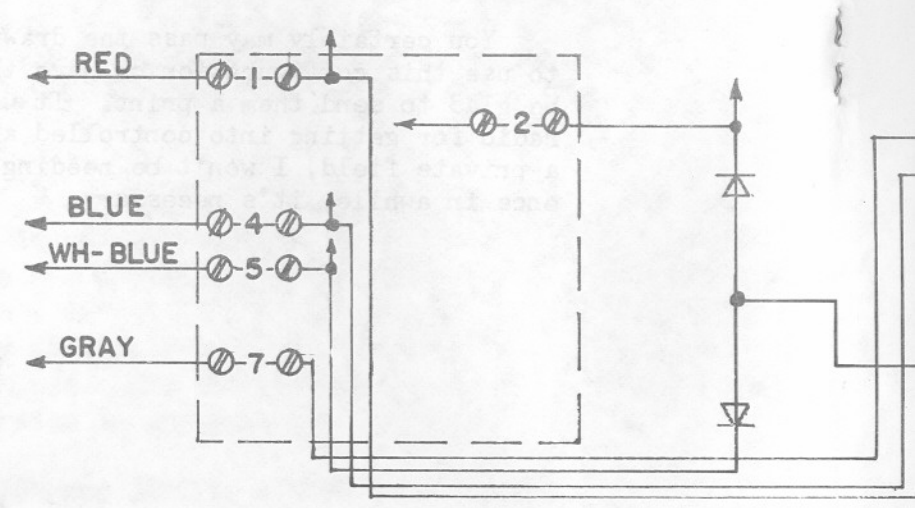
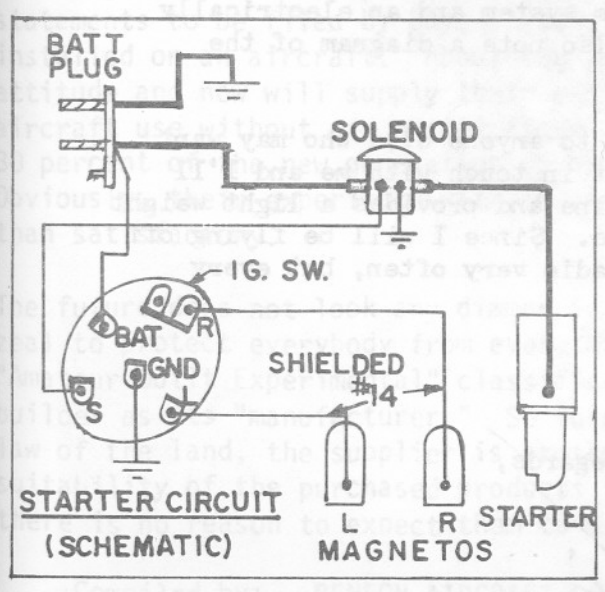
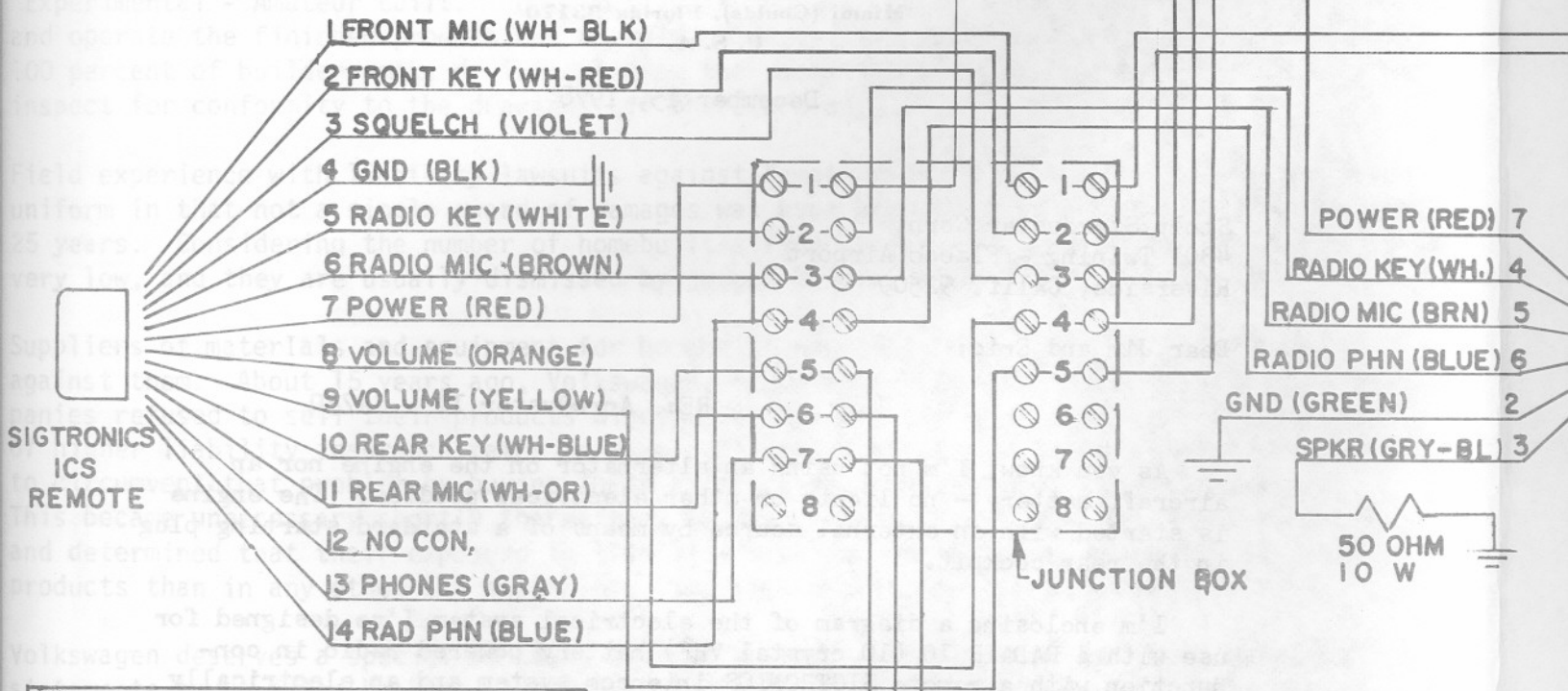
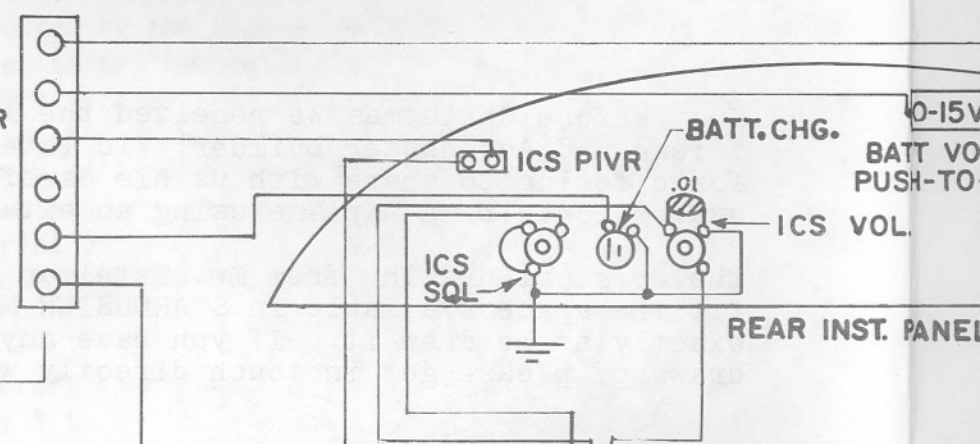

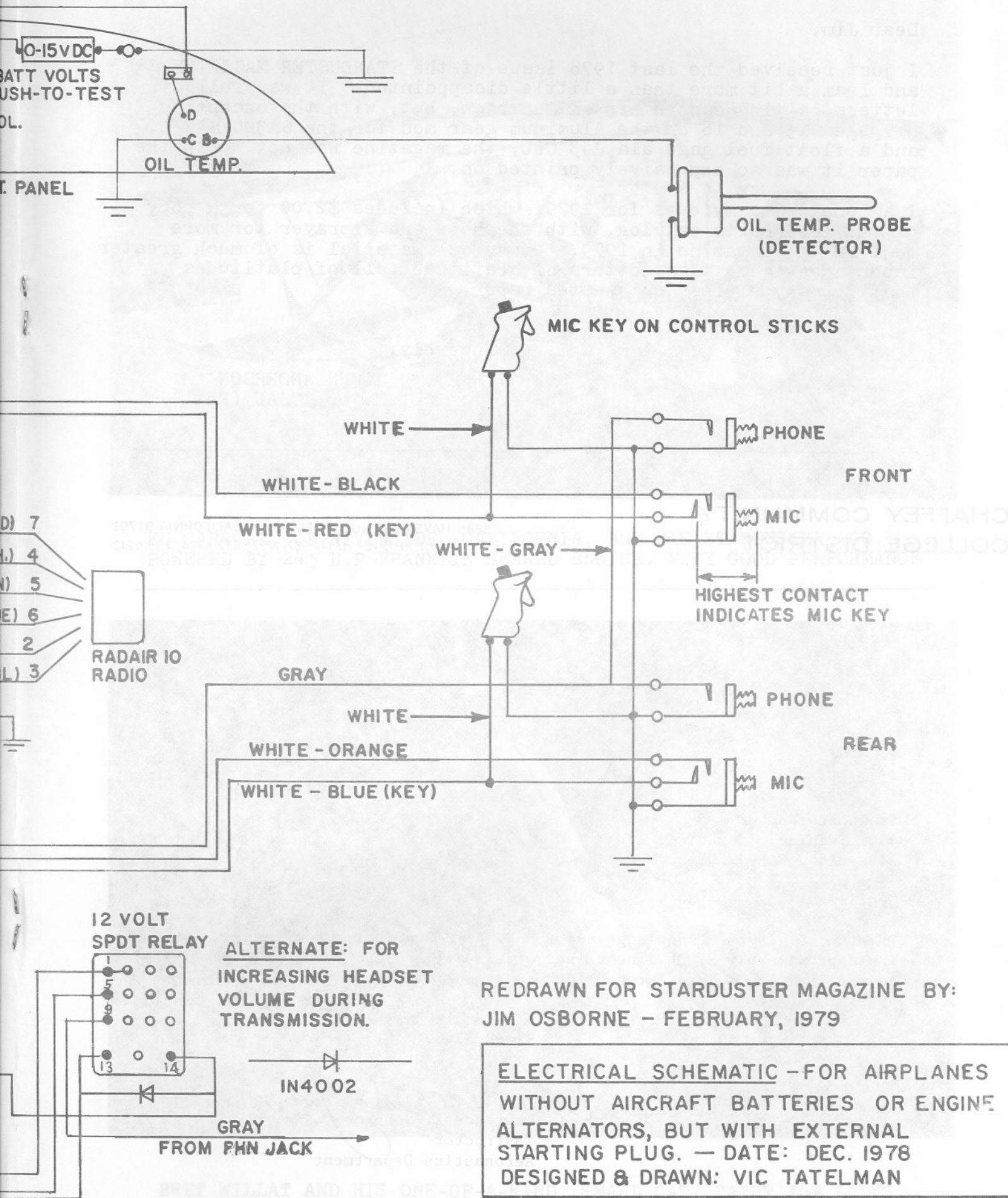

REDRAWN FOR STARDUSTER MAGAZINE BY:
JIM OSBORNE - FEBRUARY, 1979

**ELECTRICAL SCHEMATIC - FOR AIRPLANES WITHOUT AIRCRAFT BATTERIES OR ENGINE ALTERNATORS, BUT WITH EXTERNAL STARTING PLUG. - DATE: DEC. 1978
DESIGNED & DRAWN: VIC TATELMAN**

Dear Jim,

I just received the last 1978 issue of the STARDUSTER MAGAZINE, and I am a bit more than a little disappointed. It was full of letters patting each other on the back, but, with the exception of pages 15 and 16 on the Aluminum gear mod for the SA300/SA750, and a float fuel gage ala J-3 Cub, the magazine was not worth the paper it was so expensively printed on.

I am enclosing my dues for 1979, which includes \$2.00 for a copy of the 1979 Parts catalog, with the hope and a prayer for more meat in the magazine in 1979. Technical material is of much greater importance to me than letters of gratitude full of platitudes that in many copies just wastes paper.

Sincerely,

GLENN ANDERSON
Major, USAF (Ret.)

CHAFFEY COMMUNITY
COLLEGE DISTRICT

5885 HAVEN AVENUE, ALTA LOMA, CALIFORNIA 91701
TELEPHONE: (714) 987-1737, 822-4484, 735-0242

January 22, 1979

Stolp Starduster
4301 Twining
Riverside, CA 92509

Gentlemen:

This letter is to acknowledge and thank Stolp Starduster for donating approximately 2,000 linear feet of streamlined and round tubing to the Chaffey College Aeronautics Department in the 1978 school year.

Sincerely,

Lawrence X. Johnson
Lawrence X. Johnson
Instructor
Aeronautics Department

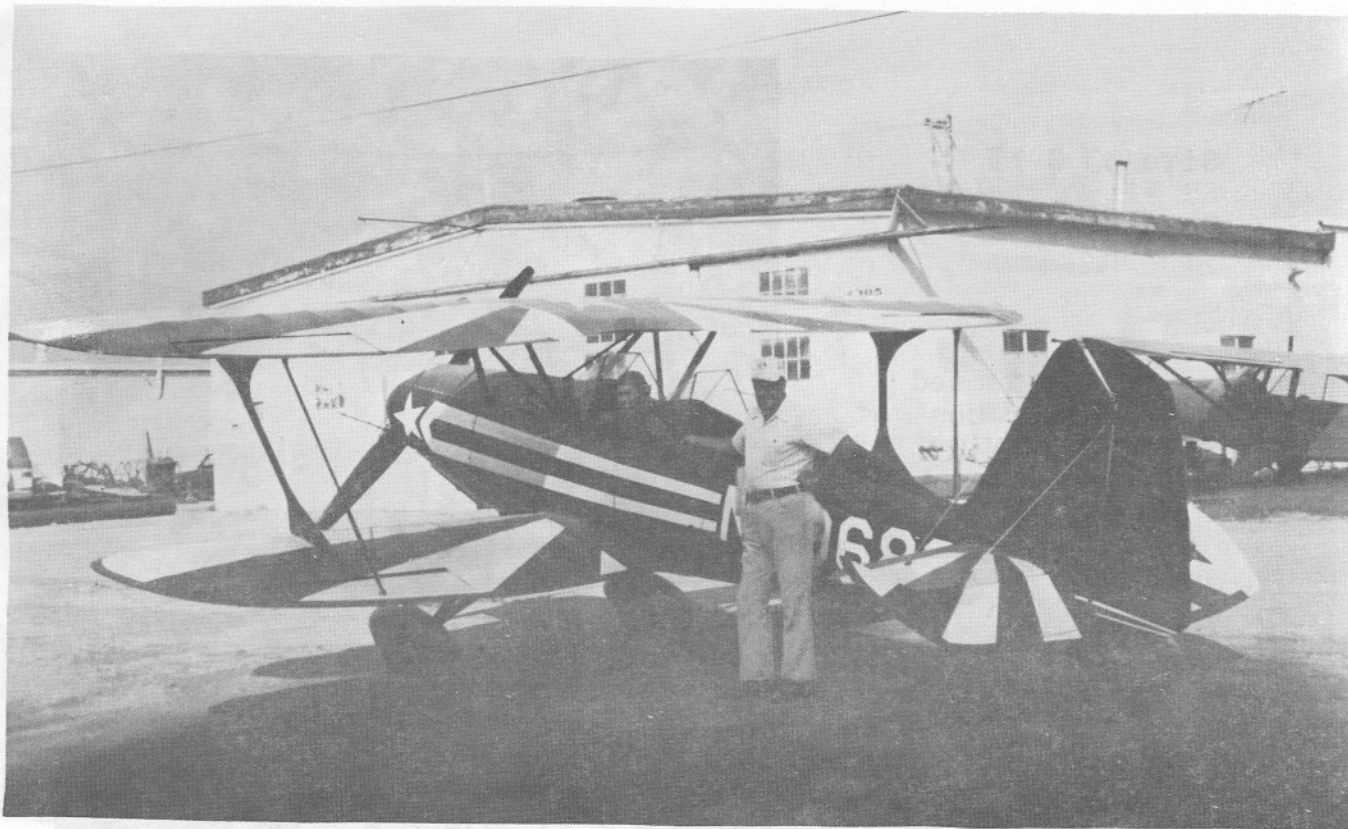

ED CARROLL, OF RIVERSIDE, CALIFORNIA, AND HIS STARDUSTER TOO. POWERED BY 245 H.P FRANKLIN GEARED ENGINE. VERY GOOD PERFORMANCE



BRET WILLAT AND HIS ONE-OF-A-KIND, SNARL CAT. PAINT JOB LOOKS VAGUELY FAMILIAR.

Site 33 C-13
 SS #1
 Castlegar, B.C.
 VIN 3H7

Eric,

Please find enclosed
 \$10.00 to cover cost of
 the STARDUSTER MAGAZINE.

Also, sending along a
 couple of shots of the
 Canopy installation
 on my STARDUSTER TOO.

The installation is
 all fiberglass- epoxy
 and was laid up on the
 turtle deck with the
 canopy in the full
 forward position, and
 makes for a nice fit
 all around.

Thanks again for your
 help.

Sincerely,
 DEL TORGALSON

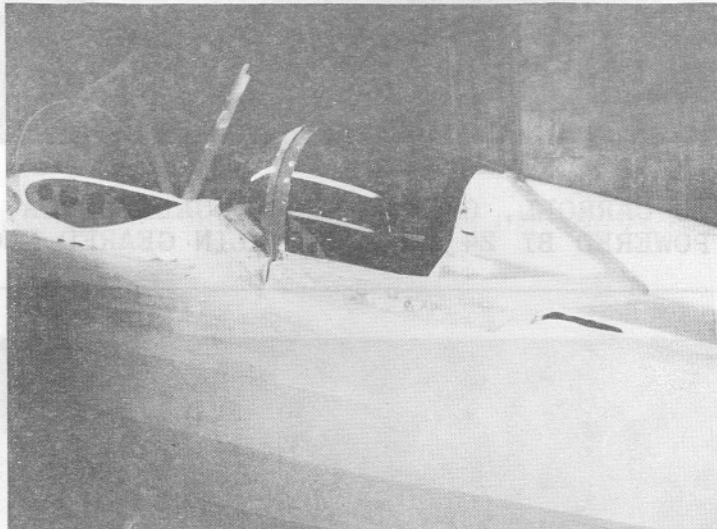
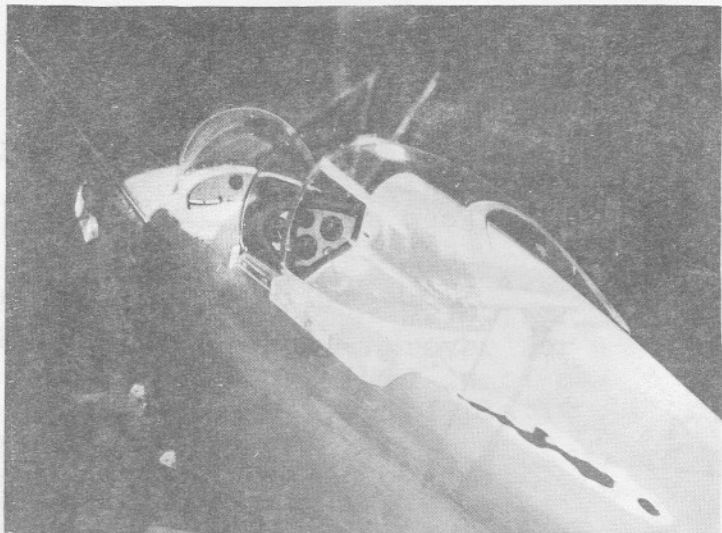

Melbourne Beach, Fla.

Dear Eric and Jim,

Inclosed are some pictures of my STARDUSTER TOO. I am conducting
 Taxi Tests at this time, and hope to be in the air soon.

Will let you know how first flight comes out.

Thanks for your fine help and cooperation thruout these four years
 of construction.

Best regards,
 ORISON CLEVELAND

Ed. Note: Mr Cleveland's immaculate STARDUSTER TOO is pictured
 on our front cover this month.



A SMITH MINIPLANE OWNED BY RON HEIMBECK, OF APPLE VALLEY, CALIFORNIA
 RON IS PRESENTLY BUILDING A STARDUSTER TOO, AND IS PRETTY FAR ALONG



CHUCK WENTWORTH AND HIS OUTSTANDING STEPHENS AKRO. CHUCK HAS BEEN
 A GOOD FRIEND AND CUSTOMER FOR YEARS. HE IS ALSO GAINING DESERVED
 RECOGNITION FOR HIS AEROBATIC AND MIDGET RACING SKILLS.

21726 Merridy Street
Chatsworth, California
91311

Dear Jim,

Just wanted to thank you for the ride in the Acroduster Too a couple of weeks ago. Eric handed me the goggles and asked "What I wanted to do?"

I told him I was thinking about building an Acroduster, and I just wanted to see what it was like.

We stood by the plane and kicked rocks while he outlines the flight plan. "We'll climb out over the Aerobatic Area, to 3500' and right into a full power stall; then a barrel roll, power off departure stall, and loop. Then you can take it for a while."

Well, here is deposit check for a wing kit. I will pick it up next week, when it is ready.

Looks like I will have the pleasure of talking to Eric, Hanako, and you quite a bit in the near future.

Talked to Gary Solmi yesterday. We are going to get together in a couple of days to discuss the two dusters he has built. Thanks for his phone number

Happy Holidays to you all.

See you soon,

JIM MCKEEHAN

ONE OF OUR PITTS
BUILDING CUSTOMERS
IS GERRIT VANDERZIEL
OF ROCHESTER, N.H.

HE IS THE OWNER-
BUILDER OF N7GV.

THIS BEAUTIFUL
BIPLANE IS BASED
AT SKYHAVEN AIRPORT

FROM THE BACKGROUND
ALL YOU OSHKOSH
GOERS CAN SEE WHERE
THIS PICTURE WAS
SNAPPED.

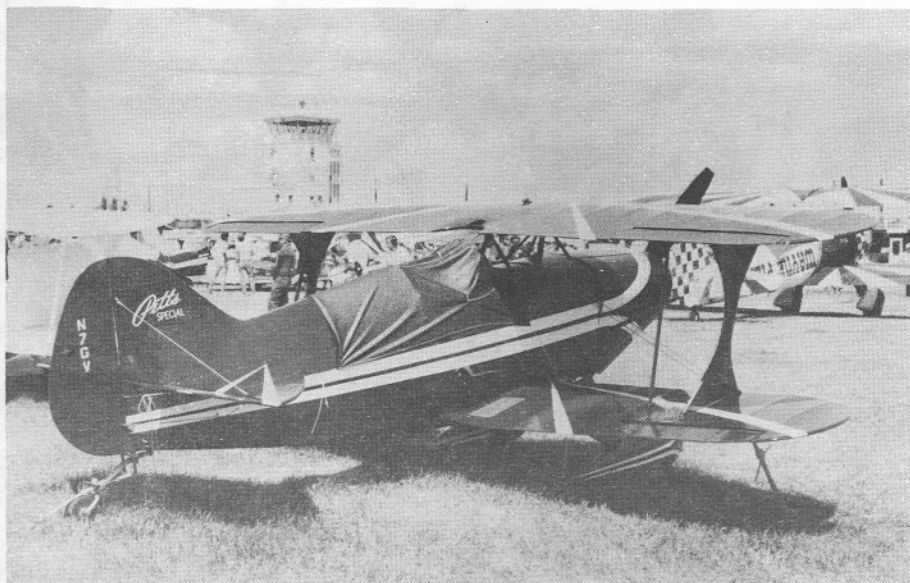

Ed. Note: Mr Cleveland's outstanding skills and his outstanding skills, CHUCK HAS BEEN A GOOD FRIEND AND CUSTOMER FOR YEARS. HE IS ALSO GAINING DESERVED RECOGNITION FOR HIS AEROBATIC AND MIDGET RACING SKILLS.

2230 S.E. Yamhill #5
Portland, Oregon, 97214

Dear Jim,

Sorry to hear about the model X Acroduster, but at least John got out O.K. It's great to see John do so well in Aerobatic Contests in the Acroduster.

I think the STARDUSTER AIRCRAFT in general are under rated as aerobatic aircraft. I have flown my STARDUSTER TOO in three contests, (Sportsman), winning my second one.

I flew my STARDUSTER TOO the first time in March, 73, with a Lyc GO-435-B (Mil 0-435-2), 235 H.P., and 93" Aeromatic prop. I have since installed GO-480 Cylinders with high compression pistons, and a Hartzell three bladed Constant speed prop. My engine now puts out 295 H.P.

At the present time, the airplane is down for a few more modifications and paint.

I am trying to cut as much weight as possible, and am interested in the spring aluminum landing gear mod you presented in the OCT. STARDUSTER MAGAZINE. How much does the gear weigh? What is the vertical distance from axial center line to the point where the gear mounts to the fuselage. (Needed to determine prop clearance.) Cost? As you can see from the photo, I have a spring steel gear installed, but is it heavy.

Also, I am interested in the formed aluminum trailing edges for the wings. Are they made in one piece, and then cut for shipping? In other words, can you supply them for my nonstandard aileron wings? (One bay longer than normal inboard, 1/2 bay longer outboard.) Price?

Find enclosed a picture of my Duster, and a check for \$6.00 for the Duster Mag for 79. Keep up the good work with the magazine.

Thanks,
KEN MCDONALD

ANSWERS TO KEN'S QUESTIONS: The weight of the one gear we have installed was 42 pounds. This was after the gear legs had been streamlined, and a lightening hole put in the flat center.

Gear extension length is 30". Cost is \$500.00 for the gear, \$55.90 for the Cessna axles and nuts, and \$39.20 for fuselage modification material.

Formed aluminum trailing edges are made in one piece, and can be shipped in one piece. Therefore, they could be used for non-standard ailerons.

For a picture of Kens airplane, see next page.

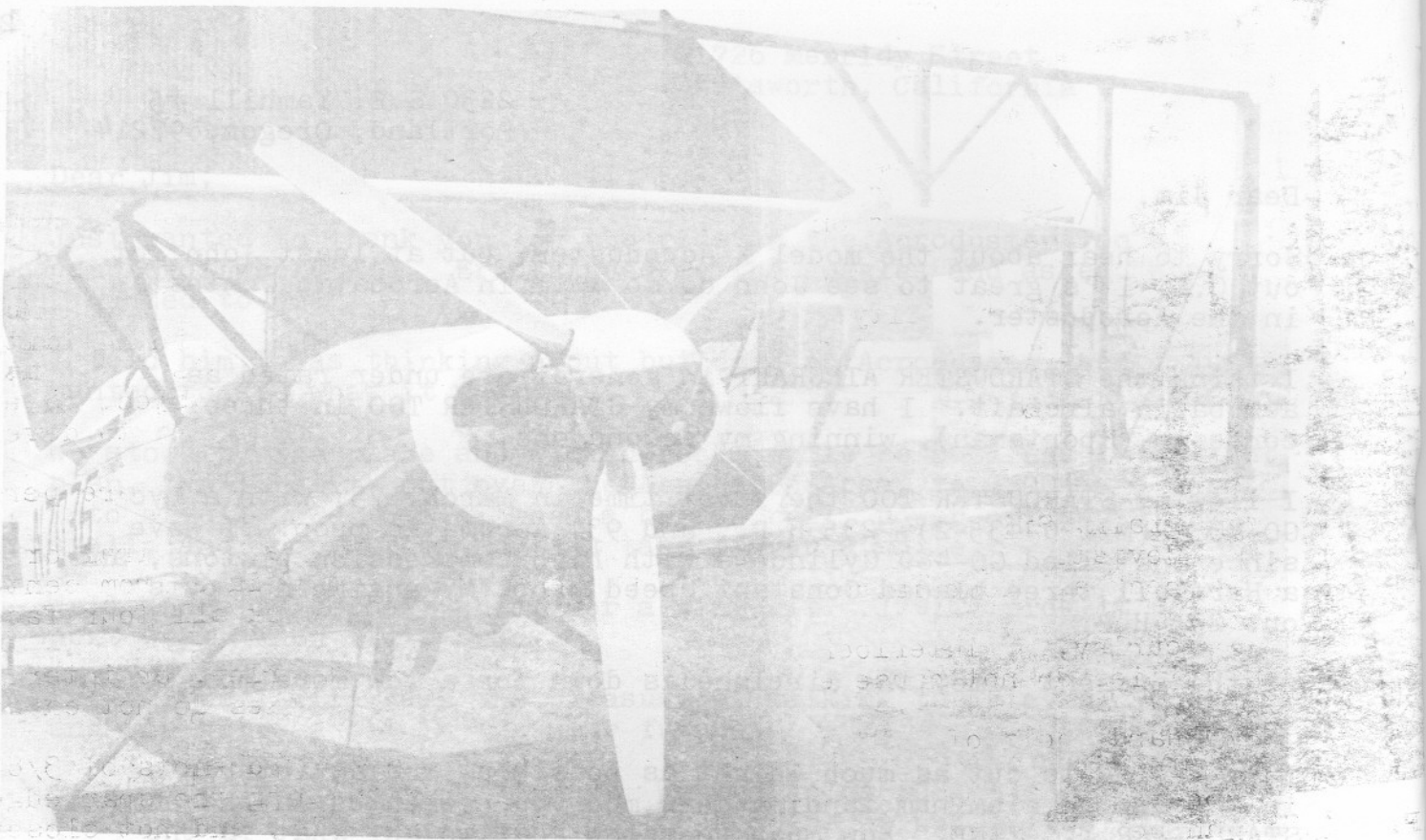

A PICTURE OF KENNETH MCDONALDS 295 H.P. STARDUSTER TOO



STARDUSTER TOO SEEN AT MERCED, CALIFORNIA. OWNER UNKNOWN

2016 South High
Denver, Co. 80224

Dear Eric and Jim,

We were very sorry to hear about model X Acroduster, but glad John got out okay.

While showing the latest issue of "STARDUSTER" to an engineer pilot at Rawlins, Wyoming, I got called to work, and therefore lost it to him.

So, enclosed is my check for continued subscription, and please send me another to replace the one I lost.

We are still very grateful for the wing information you sent us for the "WICHAWK", so if the check is slightly over the amount, please use the surplus towards restoration of the X Acroduster.

Sincerely,
DON SAVAGE

MR. ERIC SHILLING. Esquire
Chief Throttle Pusher
Stolp Starduster Corp. of America

Sir;

This comes to you from Eskimo village of Roebec-Arctic Circle-Scandinavia- and I'm a Reindeer Stage Coach Driver-and you have written in our clubpaper-Sportaviation Aug 78- by way of reprint.

The gasoline vent system could certainly be improved on-Why not use the venturi system all the time. So, a slight overpressure is had ABOVE the main fuel supply. Three years ago, in Spav, was a story of a Doctor in-Ithink-Chicago area- with a homebuilt, and he had main tank in wing, then a smaller tank nearer the engine. And he too wanted some pressure in the system. So, he put the pressure between the two tanks. So, in taxiing, all went well. When he took off and climbed, pressure emptied little tank- and pushed gas in main tank backwards. So, engine died of fuel starvation, and he crashed- destroying plane and heavily injuring himself.

How a Doctor can be a physican when a pillermixer is thata stupid is behoynd me and US Medical Board of responsibility and Fitnes for the Chosen Profession. And how they have built planes for 70 years and not yet understood this detail of feeding duel to an engine-is darn well behoynd my understanding. In Club Piper here-a mechanical pump feeds engine-and-in series- there is also an electric pump- and they never crash from lack of fuel. (But they do crash from other reasons. One member (and only EAA member in club) took a brand new Warrior up with three others- and then turned plane upside down-coming back to normal, 10 feet of wing fell off (where the taper started.). This was about 74. And they crashed from 3000 feet into a swamp. Must say that this man-WAS- a reskless and unresponsible pilot since before, too.

I gotta feeling too- that EAAers at large- could benefit immensely from a few hours practice in sailplanes- learning to land without any power at all. As it is now-when engine conks out- most of them lands short of that ditch and smash the great love- more or less unnecessary- had they know the engine out actual sinkrate beforehand.

GASCOLATOR IDEA IS IMPORTANT TOO- and here- we oughta have one on cars and trucks too- especially the diesels. Second best choice is pouring a pint of spirit in the tank. It mixes and takes the water along. Recently gas companies decided to save five million a year- by not pouring in the "wintermix" in the gas. So, cars started stalling and not starting in the mornings. And motorists had to buy carburettor spirit for fifty million a year instead. Maybe it could pay Americans to both use gascolators- AND add carburettor spirits- when flying in low temperature areas (North of the Arizona deserts and Death Valley, in California.)

AMERICANS- have one advantage in USA. There are Onan and Chrysler and McCulloch and other small engines- but nobody ever give any address to dealers-or to factory- so we can write from Europe and get prices and prospects.

STOLP STARDUSTER- can do a li'l thing for US sailflyers too- that we in Europe is unable to fix.

In competitions here-pilots die all the time- because they are suddenly caught in an updraft under a cloud-canopy ices up- plane goes down with frozen rudder- but when pilot tries to jump- he can't get canopy open. So, we hear him on radio- until the moment he smashes into ground, helplessly so.

I think- it would be a simple-and necessary matter- matter to build in a "canopy opener"- before entering competitions. We can have two lugs- on the canopy, and on the frame, in plane- and simply stick in a steelrod and bend. Or, have a small hydraulic cylinder and pump that will break seal. Or, have antifreeze soaked into the sealing along the edges.

Or some more clever system that Jim Osborne and Eric Shilling can dream up- to be tested in a freezing chamber on the ground- before going into those clouds. Small explosive charge in two to four places is still another solution- of sorts. Probably-had they had a small hammer along- they could have belted the ice away enough to get canopy open in a few seconds- but this they did not- in spite of men being killed all the time the years beforehand in competition.

So-- in name of Life Preservation - I heartily suggest that- if you don't wanna waste time designing a super pushbutton canopyopener that you at least write a letter to US Hq of sailflying, and ask them to please bring along a li'l hammer in hi-flying- so they can belt the rim and joint of the canopy around, and break the ice- inch by inch.

I would also read your magazine for a year-if I may- please.

Sincerely,
 B. MOLINDER
 Bankgatan 15
 S 902 48 UMEA
 SWEDEN



BERT MORECRAFT, FROM HARVEY STATION, NEW BRUNSWICK, CANADA, AND HIS WINTERIZED STARDUSTER TOO. IT SPORTS SKIS, AND A CONT. 0-300D ENGINE. IT LOOKS LIKE A GREAT WAY TO SPEND THE WINTER.



NEW STARDUSTER TOO, BY MAX CLOVER, OF RIVERSIDE, CALIFORNIA

84 Sherwood Street
Portland, Maine
04103

Dear Jim,

Please disregard my last letter concerning my not receiving the October STARDUSTER MAGAZINE. Two days later I received the magazine on December 19th.

Enclosed please find my check for \$6.00 for another year of the STARDUSTER MAGAZINE. Like I told you before, and I'll tell you again, I just can't afford to miss a magazine that has so much information on a bird that one is building. I started my project February 16, 1972, serial number 1374.

I kind of slowed down a bit on account of the cold weather that we have here in Maine, but I still plug away once in awhile.

Sincerely,

A. J. MAZZIOTTI

Memphis, Tennessee

Dear Jim,

I have to start this letter with an apology. Thru foulups too numerous to recount, I find I have owed you money for an extended period of time. For this, I am sorry. I do not like to owe anyone, if I can help it. I'll tell you what happened next time I call.

Sorry to read about your Acro I. Also your photo albums. Went against your own advice, didn't you? Seems I remember you do not recommend the Postal Service. Somebodies little bot has some pretty airplane pictures to look at

More later,

Jess

1020 N.W. 39
Topeka, Kansas 66618

Dear Jim,

Sorry to hear about your X model. Glad John was unhurt.

Airplane building in Kansas this time of year is slow. Just had 22-1/2 days during which temperature did not get up to freezing, and went as low as -17 degrees on several nights. Good incentive for finishing the wings in my basement shop. Another blizzard this morning. Doing some paperwork while waiting for the wind to drop off so I can plow the drive to the County road, and rejoin civilization. Really in no hurry, because the County road is still closed by drifts. If I ever run out of peanut butter, things could really get tough.

Best Regards,

HALSEY HINES

Dear Jim,

39LB has 180 hours now, with 0300D 145 H.P.

It has been a lot of fun, and will do just what it is supposed to. This will fourth season. We are well pleased with the plane and your company.

Thanks very much, Les Boyer

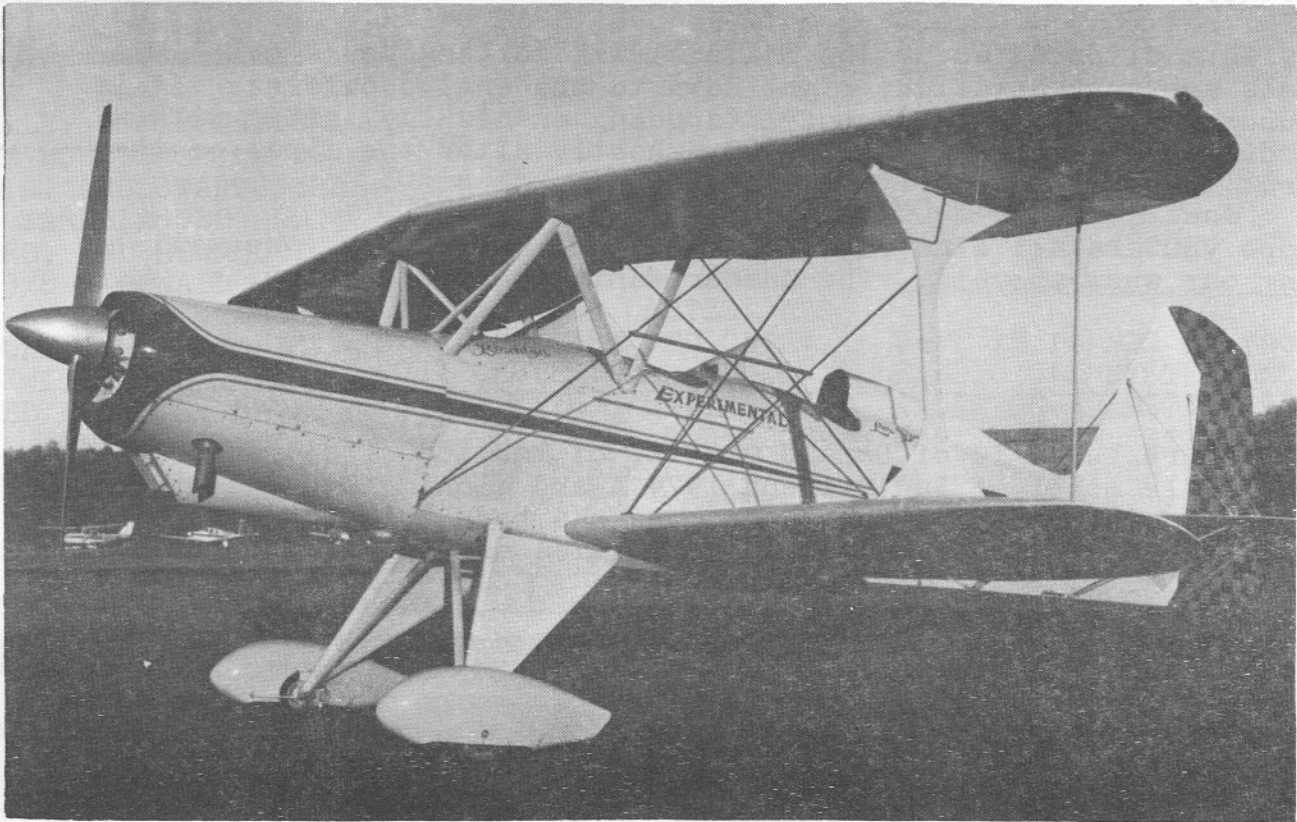

STARDUSTER TOO
UNDER CONSTRUCTION
" BY R.J. CLIFFORD
OF ISLINGTON,
ONTARIO, CANADA
M9B 3C6

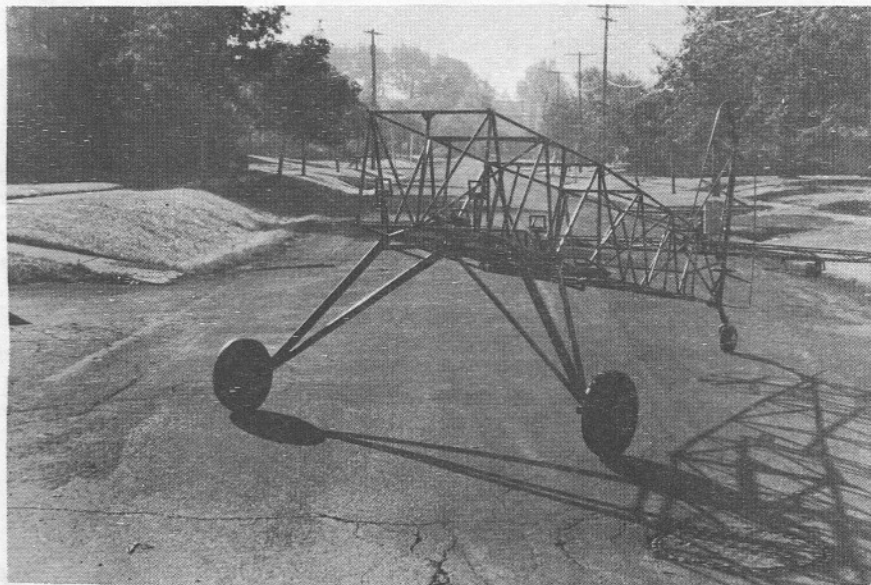

936 Roscoe
Green Bay, Wisconsin
54304

Dear Jim,

It was good seeing you at Osh kosh again this year.

Those two airplanes you had here were sure a pair of beauties. I watched them both leave Osh kosh, and they went out like a pair of homesick angels. A thing of real beauty, just watching them fly together.

This is a clipping about the fellow I was telling you about. His models are very detailed, right down to the engine baffles. It is my understanding that the model is going on display, along with a Starduster Too, in the EAA Museum, shortly after the first of the year.

I hope you are all fine out there in sunny California. We will be using our snow shovels. The summer went much too quickly.

Sincerely,
Carl Buergi

The picture below is of Donald Gruett, of Manitowoc, Wi, and his exact scale model of Bud Giffens 1974 Award Winning Starduster Too. Gruett is a pilot and plane owner, who has been building models for about six years. Dave says the model flies as well as the real thing.

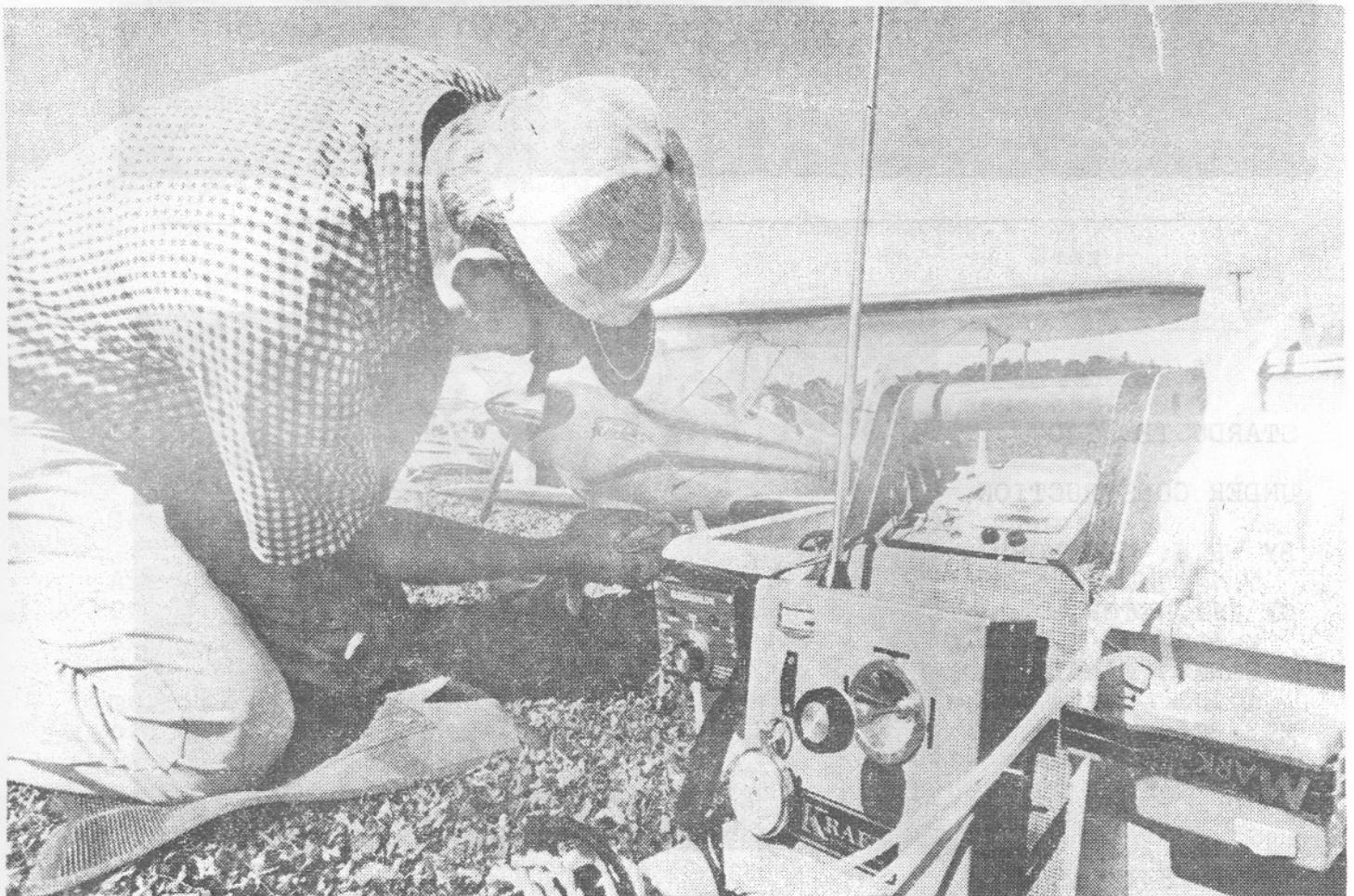

Classified Ads

ADVERTISING CLOSING DATE: JANUARY 1, APRIL 1, JULY 1, OCTOBER 1.
 CLASSIFIED ADVERTISING RATE: \$3.00 PER COLUMN INCH-MINIMUM CHARGE \$3.00
 MAKE CHECKS PAYABLE TO STOLP STARDUSTER CORP. THANK YOU.

FOR SALE

FOR SALE: ONE DYNAFOCAL ENGINE MOUNT FOR 0-320 LYCOMING AND STARDUSTER TOO. SANDBLASTED AND PAINTED, AND REAMED TO TAKE 3/8 FIREWALL BOLTS. BUILT BY STOLP STARDUSTER CORP. NOTHING IS WRONG WITH MOUNT. I CHANGED ENGINES. SAVE MONEY. ONLY \$175.00. JON NACE- 14314 IRELAND ROAD-MISHAWAKA, INDIANA

FOR RENT- HOUSE WITH HANGAR IN BACK. TWO BEDROOM. MOJAVE DESERT NEAR VICTORVILLE, CAL. USE DESERT ROAD IN FRONT OF HOUSE AS LANDING STRIP. VERY REASONABLE RENT. AVAILABLE FOR APPROXIMATELY TWO YRS. CONTACT:

CPT. DAN MCCONNELL
 NAVY FLIGHT DEMONSTRATION SQUADRON
 NAVAL AIR STATION
 PENSACOLA, FLORIDA
 32508
 Ph (904) 452- B-L-U-E

PARACHUTES-PARACHUTES
 The best Available---
 SEAT PACK OR BACK PACK
 ONLY 14 #- MADE TO FIT
 YOU. COLORS AVAILABLE
 ARE RED, GOLD, BLACK,
 BLUE, AND ORANGE----
 ALL WITH BLACK TRIM-
 INCLUDES CARRYING CASE
 OF MATCHING COLOR---
 LOW SPEED, NON-ADJUST-
 ABLE CHUTE, WITH CAR-

RYING CASE, \$460.00.
 FOR AN ADJUSTABLE HAR-
 NESS, IN CASE SEVERAL
 PEOPLE WILL BE USING
 CHUTE, PLEASE ADD \$20.00.
 FOR A TEMPER FOAM SEAT
 CUSHION IN PLACE OF STD
 CUSHION, PLEASE ADD \$19.00.
 ABOVE IS FOR LOW SPEED
 (150 M.P.H.) CHUTES. ALSO
 AVAILABLE ARE STD CATE-
 GORY CHUTES. NON-ADJUS-
 TABLE, WITH CARRYING
 CASE, \$530.00. ADD \$20
 FOR ADJUSTABLE HARNESS
 AND \$19.00 FOR TEMPER
 FOAM CUSHION. ORDER
 FROM STARDUSTER CORP.

BUILD AND FLY THE WORLDS
 EASIEST-TO-BUILD AND
 HOTTEST PERFORMING AERO-
 BATIC BIPLANE-- THE ACRO-
 DUSTER ONE--
 BROCHURE----\$5.00
 COMPLETE KIT--\$5950.00

NEW GEL CEL BATTERIES--
 MAKES OTHER BATTERIES OB-
 SOLETE- 12 V.-28 A.H.--
 NO SERVICING-NOTHING TO
 SPILL--DOES NOT HAVE TO
 BE ENCLOSED IN A BATTERY
 BOX- REDUCED IN PRICE-
 ONLY \$49.95, plus \$3.00
 PACKING CHARGE-- FROM
 STOLP STARDUSTER CORP.

New Mounting Rack for Gel
 Cel Batteries--Made of
 4130 Steel-- May be bolted
 to firewall--Only \$45.00
 from "STARDUSTER"

A SPECIFIC FOR A SORE
 RUMP- NEW "T" FOAM CUSHIONS

NOW MADE FROM TWO LAYERS
 OF DIFFERENT DENSITY NASA
 DEVELOPED FOAMS-- USED
 FOR THE ASTRONAUTS COUCHES
 AND WHEELCHAIR PATIENTS.
 YOU NEVER FELT IT SO
 GOOD-- \$19.95 from
 "STARDUSTER" CORP.

SAVE 18 POUNDS ON YOUR
 ELECTRICAL SYSTEM INST-
 ALLATION-- INSTALL SOLAR
 PANELS FROM "STARDUSTER"
 TO CHARGE YOUR BATTERY.
 NEAT, SIMPLE, AND LITE
 WEIGHT. MAINTENANCE FREE.
 ALMOST NO DRAG. MOUNT
 ON WINGS OR OTHER NEARLY
 FLAT SURFACE. SIMPLE &
 EASY TO INSTALL. ONLY
 \$249.50 FOR TWO CELLS,
 COMPLETE WITH INSTRUC-
 TIONS. IN STOCK. IMMED-
 IATE DELIVERY.

SIGTRONIC INTERCOM SYS-
 TEM. REMOTE MPUNTING. THE
 BEST UNIT FOR BIPLANES.
 MOUNT ANYWHERE. ONLY
 \$144.50, FROM "STARDUSTER".

COFFEE MUG--HI QUALITY
 COLOR PICTURE OF ANY OF
 OUR AIRPLANES ON IT, TO-
 GETHER WITH YOUR FIRST
 NAME AND THE "N" NUMBER
 OF YOUR AIRPLANE-- SEND
 \$5.95 TO "STARDUSTER".

STEWART WARNER OIL COOL-
 ERS. CERTIFIED. USE TWO
 FOR 200 H.P. ENGINES
 LIST PRICE-\$160.00
 OUR PRICE-ONLY \$99.50

Classified Ads

FOR SALE

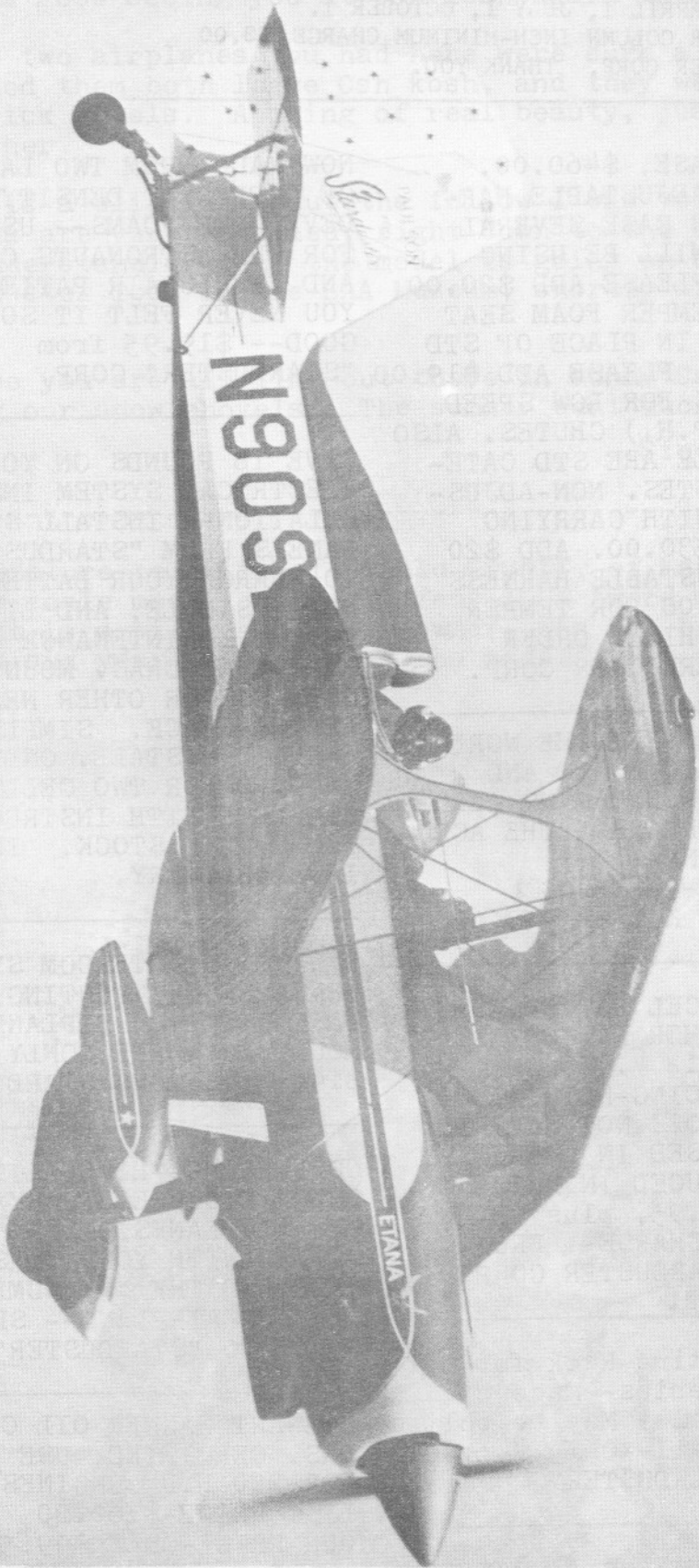

FOR SALE, ONE BIRMINGHAM ENGINE MOUNT FOR O-200I LYCOMING AND STARDUSTER 100. SANDBLASTED AND PAINTED, AND REAR END TAKE 2/8 FERRALL BONES BUILT BY BLOTT STARTERS TER CORP. WORKING AS WRONG WITH ... CHANGED ENGINE. SAVE MONEY. OVER \$2000. FOR ADJUSTABLE ... ROAD-MISMAK ...

FOR RENT-HOUSE WITH HANGAR-IN BACK TWO BEDROOM ... NEAR VICTORY ... USE DESERT ROAD IN FRONT OF HOUSE AS LANDING STRIP. VERY REASONABLE RENT. AVAILABLE FOR APPROXIMATELY TWO YRS. CONTACT: CPT. DAN MCGONNELL, NAVY FLIGHT ... STATION BOULDER, NAVAL AIR STATION, PENSACOLA, FLORIDA 32508

PARACHUTES-PARACHUTES The best Available SEAT PACK OR BACK PACK ONLY 14 MADE TO YOU. ... ARE RED, BLUE, AND ... ALL WITH INCINER ... OF MATERIAL LOW SPEED ...