

THE

# Starduster

JANUARY 1980

MAGAZINE

DEDICATED TO THE ACTIVE HOMEBUILDER



PAGE 1



The International Aerobatic Club, and the members thereof pride themselves on safety. They require two safety belts, to protect against the remote possibility that one might fail. They require technical inspections of each competing airplane prior to a contest. They have strict rules against flying too low during the contest. Violation will result in the pilot getting cancelled out for that flight.

And yet, in one area, dangerous chances are taken very frequently. No action is taken, or contemplated, by the leaders of Sport Aerobatics. Perhaps because the leaders are among the pilots who practice dangerous, sometimes foolhardy flying habits.

These dangerous habits are (1) exceeding limit "G" loads, and (2) Exceeding airspeed limitations. Most aerobatic airplanes are designed to take plus or minus 6 G loads without sustaining any structural damage. It is common practice among aerobatic aces to regularly pull up to 8 G's. Although the airplane will not break immediately at 8 G's, permanent structural damage does occur, and either extensive overhaul or catastrophic failure is likely to occur in the future due to cumulative "overgeed" damage. I have even read an article written by Charlie Hilliard warning against this very thing, and bragging that he never pulled over 7 g's himself.????

Since a pilot can always put on a more spectacular flight by flying faster and pulling more "G"s, (do five level snap rolls instead of four, with a higher entry speed) perhaps it is time for our aerobatic leaders to take some effective action against this type of flying. And I don't mean by raising the allowable "G" levels to 8 in place of 6.

The most effective action would be the development of clampon "G" meters and maximum reading airspeed indicators. These clamp on instruments would be attached to the airframe in such a manner that they could not be zeroed by the pilot in flight. They would be attached before every official flight. Exceeding the "G" limits or the Vne would give the pilot zero for that flight. This would insure that all pilots would compete on an equal basis, and would place emphasis on smoothness and graceful maneuvers instead of some of the gutrenching gyrations that pass for aerobatics in some of today's contests.

Exceeding G limits and maximum airspeed limits is much more dangerous than flying at 1400' instead of 1500'. I wonder when our leaders will recognize this and take appropriate action.

THE STARDUSTER MAGAZINE-DEDICATED TO THE PROPOSITION THAT THE ULTIMATE IN SPORT AIRCRAFT WAS REACHED WITH THE DESIGN AND DEVELOPMENT OF THE OPEN COCKPIT, TAILDRAGGING BIPLANE---AND THAT EVERYTHING ELSE HAS BEEN DOWNHILL----EVER SINCE.

TABLE OF CONTENTS

PAGE ONE, EDITORIAL----- 1

SHOP SAFETY, AN EYE-OPENING EXPERIENCE----- 3

HOW TO BUILD A BASIC BOX WELDED STRUCTURE----- 4

PRODUCT INFORMATION----- 9

FABRIC FINISHING WITH "IMRON"-----11

PROPELLER BULLETIN-----12

NEW ACRODUSTER ONE FLIES-----14

PRICE INCREASES-----12

PIREPS PAGE-----17

CLASSIFIED ADS-----30

This magazine is not copyrighted, except as noted. Permission is hereby given to reproduce any part of it, except as noted, for the benefit of Sport Aviation, providing credit is given to the publisher, STOLP STARDUSTER CORPORATION.

The STARDUSTER MAGAZINE is a quarterly publication, published four times a year. Subscription rate is \$6.00 per year. Published by STOLP STARDUSTER CORPORATION, 4301 Twining, Riverside California, 92509. Phone (714) 686-7943

A NEW ACRODUSTER ONE, now owned by CINDY RUCKER, graces our front cover. It is being flown by ED BOSE, ACRODUSTER ONE builder and pilot from Lincoln, Nebraska. Ed spent the cold weather in Riverside, keeping warm and working at STOLP STARDUSTER. He also helped fly the time off the new airplane.

On our back cover is a rather exotic shot of the ACRODUSTER ONE BUILT BY ED BOSE, and owned by HARRY BARR, of Lincoln, Nebraska. I don't know who owns the model, but the eerie old building in the background is obviously a leftover from WW 2. Thanks for the picture, Harry.

WE STILL GIVE SHORT LENGTHS OF TUBING SUITABLE FOR WELDING PRACTICE WITH EVERY SUBSTANTIAL ORDER, IF YOU ASK FOR IT. ALSO, WE STILL GIVE 10 % DISCOUNT ON THE SHORT LENGTHS RACK TO WALK IN CUSTOMERS. SO, WALK IN, YOU ALL.

3

EDWARD W. HARKER

ATTORNEY AT LAW

PHONE 243-1083

FARMERS TRUST BUILDING  
ONE WEST HIGH STREET  
CARLISLE, PENNA. 17013

Dear Jim:

Here is the article that I mentioned I would write in the hope that someone may benefit from my own bad luck.

Sincerely,

*Edward W. Harker /ers*

Edward W. Harker

SHOP SAFETY - "AN EYE-OPENING EXPERIENCE"

There are many perils associated with home workshop projects. This article deals with what can happen if you don't watch out, and what can happen if you do watch out ... the same thing happens either way. This is another way of phrasing Murphy's Law.

While trimming a 1/4" x 15" strip of stainless from the firewall of my SA750 project, I had a bad experience. You might say it was a real eye-opener. The narrow strip of scrap curled back and up toward me unnoticed as I proceeded along the cutting line. When the final cut was made, this unnoticed end, sharp as a scalpel, proceeded to dissect my right eye. Without going into details, such an injury is: messy; painful; expensive; and disabling.

My safety glasses were located nearby at the grinder, safely out of danger. [They might as well have been in Iran.] Customarily, I wore eye protection during drilling, grinding and sawing operations. In other words, in my own way I tried to be careful. Unfortunately, as Murphy's Law points out, accidents occur even when we believe we are exercising caution. Therefore, safety glasses should be worn during all shop work without exception.

Big aircraft manufacturers have safety officers on staff. But then, again, they also have accountants, draftsmen and even sometimes, eccentric engineers. Home-builders have none of these [and most wouldn't take them as a gift]. Nevertheless, each homebuilder must handle all production functions, and I want to urge all of you not to forget the duties of the safety officer. Even when no risk is anticipated, wear safety glasses whenever you are in your shop. Make this a habit. The eye is no doubt the most delicate tool and instrument you possess.

By the way, thanks to the wonders of modern medicine and several dedicated physicians, my eye will most likely be returned to service within a few months. For this I count myself as lucky, although I wish I could say I had been more cautious. The point is, if you heed the simple advice I have given, you will protect yourself from similar experiences.

Since all distances on the fuselage drawing are center to center distances, we start at the front end with a top to bottom, center to center distance of 24". Since both top and bottom forward longerons are 3/4" in diameter, add 3/4" to 24". Bottom longeron slants down at 1 degree for a distance of 56-1/2". This works out, by Trigonometry to be .986", say one inch. So, for the forward part of the fuselage the maximum depth is  $24 + .75 + 1 = 25.75$ " Now split your plywood board lengthwise so that one piece is 25.75" wide. That will leave the other piece 22.25" wide minus the thickness of the sawblade. This is wide enough, as we shall see.

Now, build your holding fixture as shown below.

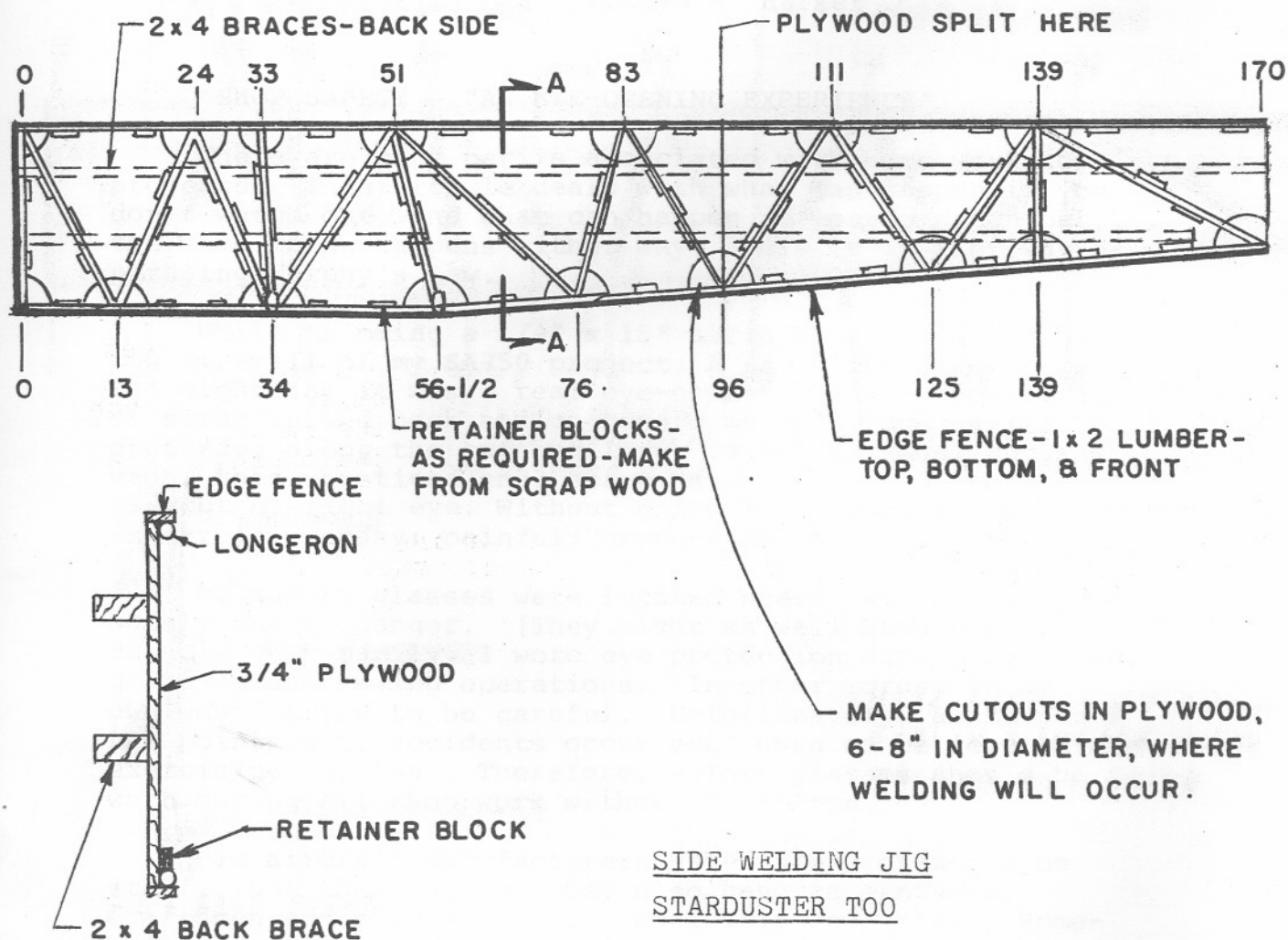

### SECTION A-A

Note that there is not any edge fence on the back edge of jig. This is because the vertical fin spar is not put in at this stage. It comes later when we join the two sides.

In laying out the side jig, lay it out to the stations given, even though you know and I know that aft of station 51 for the top longerons and 56-1/2 for the bottom longerons, the longerons bend, and the stations are foreshortened. Do not be concerned about this.

It has been allowed for in the design work. Lay the side frames out on stations, just like the sides were straight all the way back with no bend in them.

After your jig is made, cut and fit all tubing. Fit should be fairly close, within about 1/16 inch. We cut by hand using WISS R.H. cutting aviation snips. We have tried other brands, but they are not as good. Mark on the tubing with a silver pencil where you want to cut, and then cut out semicircles to approximate shape, using your WISS hand cutter. You can then get a closer fit, if required with a rotary file in your hand drill, which should be chucked in your vise.

After all tubing is cut and fit, and you have double checked to make sure the jig is flat and level, you can commence welding. At this stage, do only tack welding. Tack weld each tube in two places.

On the STARDUSTER T00, the top longerons bend inboard at station 51, and the bottom longerons bend inboard at station 56-1/2. This will make the top longerons bend down slightly, unless corrective measures are taken. The simplest corrective measure is not to weld the side members to the top longeron aft of the bend at station 51. At stations 83, 111, and 139, tack weld the side members to each other, and to the bottom longeron, but leave them unattached to the top longeron.

After both sides are cut, fitted, and tack welded, buy yourself another piece of 3/4" plywood and two more 2 x 4's. Now make a top jig. It is made the same way as the side jig, with edge fences, welding cutouts, and back braces. HOWEVER, now, from station 51, back, the stations have to be foreshortened by an amount equal to some involved trigonometric functions. the easy way is to lay out the top jig as shown below.

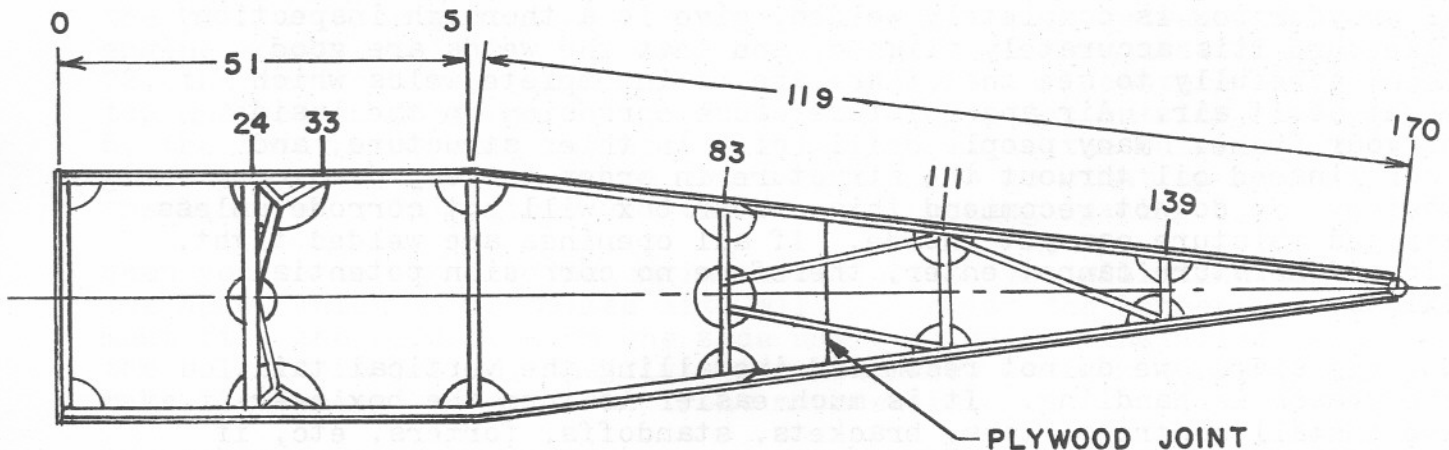

#### 2 x 4 BACK BRACES NOT SHOWN

Note that in laying out the stations aft of station 51, the stations are laid out along the edge of the jig, instead of along the center line. Otherwise, it is very similar to the side jigs.

Now we load the side frames into the top jig. Make sure the top jig is flat and level. A carpenter's level will do to determine this. Put your tack welded sides in position. Heat the top longerons to a cherry red at station 51 and bend them so that they will fit the top jig properly. Since the vertical side members are not tacked to the top longeron aft of station 51 it is very easy to now make the top longerons fit the jig properly. Support the side frames in position with wires, 2 x 4's, angles, etc, with support members clamped or tied to side frame and work bench.

Now, cut, fit and install all top cross members. Tack weld in place. Use two tacks per cross member.

Heat the bottom longerons cherry red at station 56-1/2, and bend them to correct angle. Now, tack weld all side vertical members to top longerons.

Add bottom cross members, including wing carry thru members. Use plumb bobs and levels to insure accurate alignment of basic structure. Tack weld, with two tacks per cross member. Do NOT put in the vertical tail post member.

Your basic box should now be rigid and accurately aligned. Remove it from the top jig.

You can now place the box on two sawhorses, and you are ready to begin your serious welding. Start at the front end. Weld an upper corner. Weld the opposite lower corner. Weld completely. Do not leave any unwelded gaps or cracks. Now weld the remaining lower corner, and the the last upper corner. Following this crossover welding procedure, (similar to tightening the nuts when installing a tire), proceed back along the box, welding all four corners at each station. This procedure helps cut down warpage.

After your box is completely welded, give it a thorough inspection. Make sure it is accurately aligned, and that the welds are good. Check carefully to see that there are no incomplete welds which might admit air. Air and moisture cause corrosion on the inside of your frame. Many people drill holes in their structure, and pour linseed oil thruout the structure in order to keep down corrosion. We do not recommend this. Your box will not corrode unless air and moisture can get inside. If all openings are welded tight, air and moisture cannot enter, therefore no corrosion potential exists.

At this stage, we do not recommend installing the vertical tail. The reason is handling. It is much easier to turn the box over and install controls, tabs, brackets, standoffs, formers, etc, if the vertical tail post is not on there. Therefore, delay this part of your box until a later date.

After your welded structure has had standoffs, formers, brackets, controls, etc, added to it and it is basically complete, it is time to add the tail assembly. Do this by cutting and fitting the Fin tail post. Do not weld yet. First make the hinges. Make all hinges in one piece, then cut the individual pieces out of the long piece. Ream the hinges. Now, locate and weld hinges, taking every effort to keep them in exact alignment.

Check the hinges after welding to Fin Spar. Re-ream, if necessary.

Locate your box on sawhorses, and level, both fore and aft, and side to side. Install the Fin Spar, using your carpenter's level to be sure it is exactly vertical. Now weld to top and bottom longerons. Add any other part of the fin that may be called for on your plans. After welding is completed, recheck to see if your hinge holes are still in alignment. If not, you may have to heat one or more weld clusters, and, using jacks or clamps, take whatever measures are necessary in order to get good alignment. If the hinge holes are in anything less than perfect alignment, your structure will waggle back and forth as the rudder is moved.

The top square of your seats can be bench fitted and welded. Install the legs and weld in position. No problems should be encountered.

The wing carrythru members, at stations 34, and 56-1/2, are bushed to accept the wing attach bolts. It is important that these bushings be in perfect alignment. To achieve this perfect alignment, it is best to weld in one piece of 7/16 x .065 4130 tubing that is long enough to go from station 32 to station 58. Make sure the tubing is straight. Weld in place at both wing carrythru members. Weld tight so no air or moisture can enter. Leave this long bushing stock in place, until you go to attach the wings. Then cut the bushing stock to fit exactly between the wing spar fittings. You then will have both perfect alignment, and a perfect fit.

On an ACRODUSTER TOO, the basic box is a little more complete than it is on a STARDUSTER TOO. The vertical fin is completely built, and you have to add engine mount bushings. The vertical fin gives you more elding to do on the fin spar, and increases the chance of having hinge misalignment. Be careful here.

The engine mount bushings also have a possibility of error in construction. On section A-A, the top dimension of 28" is the centerline distance between the longerons. The 27" dimension at the bottom, and the 20-1/2" side dimension are centerline distances between the engine mount bushings. Now look at view K-K. Notice that item no. 72, the vertical box member at the firewall, is not centered on the top and bottom longerons. It is offset 1/8" to the outside. Items 8, the front crossmembers, are likewise offset to the outside. This gives you room for the engine mount bushing to go right up against the longeron. This gives you the correct bushing spacing.

When you go to install the engine mount bolts, you will find that the head, which is installed aft, will not clear the longeron. You must file the head down on one side until it can be installed. After the bolt is installed, the flat side will keep it from turning, and make tightening the nuts out front much easier.

On both the STARDUSTER TOO and the ACRODUSTER TOO, you have a choice between the regular landing gear, and the new spring aluminum landing gear. If you choose the regular gear, it is a good idea to make up the truss assembly, which holds the shock cords, on the bench. You can then install the truss as a unit.

Your basic box is now complete. Before it becomes a part of the complete welded assembly, it may get a little rusty on the outside. Don't worry about it. After all welding is complete, sandblast and paint immediately. you will have a strong and beautiful framework.



## PRODUCT INFORMATION

NASA INLETS - On the new ACRODUSTER I, owned and flown by Cindy Rucker, we installed a fiberglass NASA inlet for the pressure carburetor, as shown below. This type of inlet is excellent for engines with rear mounted carburetors, or injectors. They will work well for either 360 or 540 C.I. engines. On a 360, you pick up about an extra inch of manifold pressure.

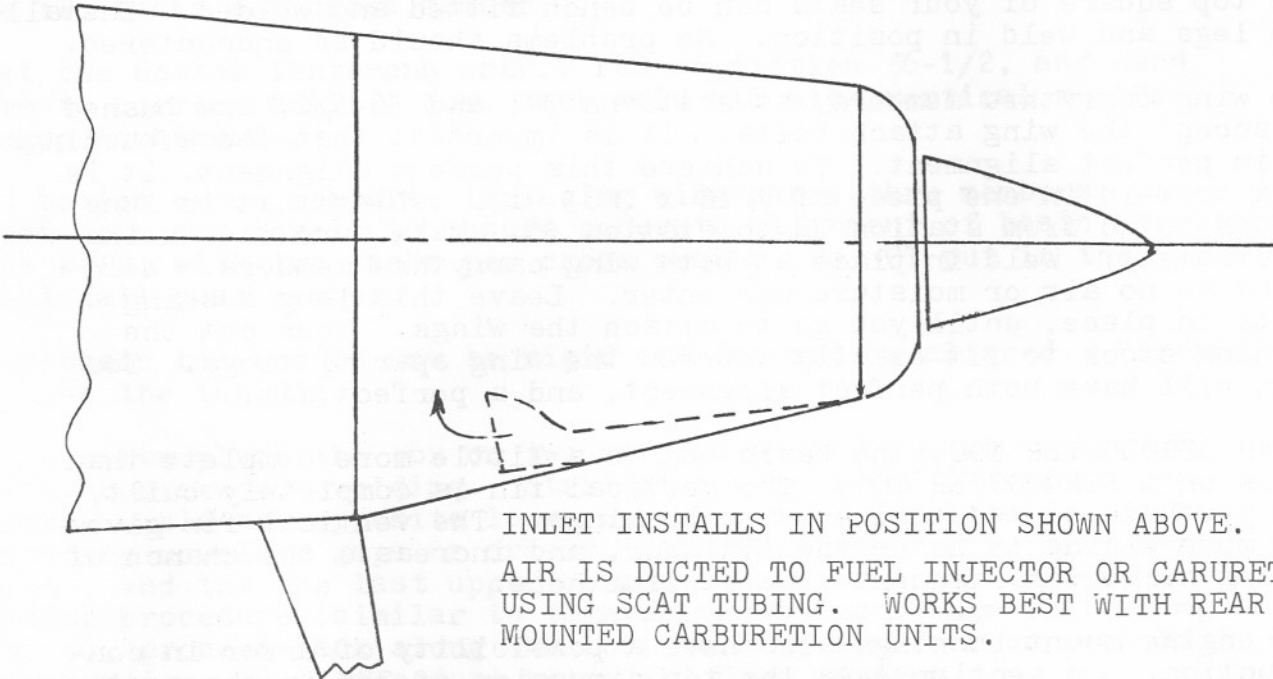

INLET INSTALLS IN POSITION SHOWN ABOVE.

AIR IS DUCTED TO FUEL INJECTOR OR CARURETOR, USING SCAT TUBING. WORKS BEST WITH REAR MOUNTED CARBURETION UNITS.

NEW STARDUSTER WINGS - We have built several sets of wings for a STARDUSTER TOO, using a new design. The most significant feature is use of a modified 23012 airfoil, in place of the popular M-6.

This airfoil should give slightly better performance in the positive G mode, and significantly better performance when pulling negative G's.

Other improvements include redesigned drag truss, featuring aluminum tubing, and redesigned ailerons and controls. The ailerons should be lighter and give a faster response. The redesigned controls are completely beneath the floor, out of possible harms way.

These new wings are only available ready built, from Stolp Starduster Corporation. Eventually, they will be incorporated in the plans. However, this will not be for some time yet, probably a year or so from now.

In the meantime, if you want a set of ready built wings, contact me, Jim Osborne, at Stolp Starduster Corp.

A UNIQUE OIL/GREASE- We have recently started stocking and selling a most unusual combination of oil and grease. The product comes in a spray can, and is applied like WD-40 or any other spray-applied penetrating oil. It acts as both a lubricant and a rust preventive.

The unique feature of this penetrating oil is that in about 15 minutes after application it turns into a light, solid grease. The cured grease is water resistant (the company says waterproof) and is stable to 400 degrees F. It will lubricate and prevent rust on any metallic surface. It comes in extremely handy at annual time for lubricating hard-to-reach areas .

The name of this little wonder product is LIQUI-LUBE, and it is available from STOLP STARDUSTER CORP. FOR \$10.95. (A little high, but worth it.)

---

TEFLON LUBRICANT-Another penetrant lubricant we have recently started using is called TRI-FLON. It is a penetrating oil carrier similar to WD-40 and LPS, but it also carries teflon, in suspension. This teflon, in our opinion, makes it better for minimum-friction applications. I use it at home, and I sprayed the mechanism of an old grandfathers clock which hadn't run for years. It ran for a little over three months on that one application of TRI-FLON. For \$6.95 you can buy a lot of lubrication here.

---

SMOKE SYSTEM UPDATE- STARDUSTER SMOKE SYSTEMS have been improved with the substitution of a new, lighterweight, 12 volt pump. This replaces the surplus 24 volt pump that was previously used and operated as a 12 volt pump.

The new pump is much smaller and lighter. For anyone wanting to upgrade thier smoke systems, it is available for \$41.95.

For smoke systems on airplanes without electrical systems, a battery is necessary. We have an excellent little gel type battery that is available. It is rechargeable, non-leaking, (nothing to leak), and weighs only 4.6 pounds.

Recharging is done with an automotive, home type charger that puts out 1/2 to 1 amp initial charging rate.

The electrical rating is 6 amp hour at the 20 hour rate. (.3 amps per hour.)

Dimensions are 5-1/2 x 3-7/8 x 2-3/4 inches. It will fit in corners and crevices that bigger batteries won't go in.

The price of this little Gel Cel jewel is only 49.95. For minimum size and weight, and moderate current applications, you can't go wrong.

FABRIC FINISHING WITH "IMRON"

One of the best aircraft finishing systems we have ever tried involves imron paint. Here is how it goes, on a fabric covered airplane.

First, cover the airplane with dacron, glueing the fabric down with sureseam fabric cement. Heat shrink with a hot iron, or hot air gun. Then brush or spray, (opinion is divided on this) 2-3 coats of clear nitrate dope. This dope is thinned to easy working consistency.

Add your pressure sensitive, rib stitching tape over the ribs. Do your rib stitching, being careful to space the stitches the right distance apart, and then dope on your dacron tapes.

Add several more coats of nitrate, nontautening, clear dope until the surface of the fabric is bright and shiny.

Up to this point, everything has been according to the standards set forth in the ceconite covering manual. Now, we diverge a bit.

Instead of using butyrate dope, lay on about three coats of nitrate silver. Now sand by hand until an absolutely smooth surface is obtained. Lay on one or two more coats of nitrate silver, and check for smoothness and thin spots.

If all is satisfactory, shoot the covering with Imron which has been loaded with four times the amount of silver paste that was in the nitrate dope. Normally we use 4 ounces of silver paste per gallon of nitrate dope. In the first coats of Imron use 16 ounces of silver paste per gallon of clear Imron. Apply one wet coat, and allow to dry overnight.

The next morning scuff sand with 360 grit sandpaper.

Apply base colors, succeeding colors, and striping of Imron urethane enamels.

Apply a clear coat of Imron over all the colors, as a last step.

The advantages of using Imron include the fact that Imron goes equally well over metal or fabric. When finishing fabric with colored dope, this is not so. The metal parts have to be painted with paint, and it is sometimes difficult to match colors exactly.

The disadvantages are; (1) Slightly greater weight than a dope finish; (2) Toxicity. This last disadvantage can not be overstressed. All two part, or urethane paints and dopes are highly toxic. These finishes combine and chemically cure in your lungs, if breathed, and are cumulative, and impossible for the body to shake off. By all means, when using Imron, use the best mask protection you can obtain. Be at least twice as careful as you would be with ordinary paint. If possible, use an oxygen mask with a pressure feed, so that you will not breathe any of the urethane fumes. Do that, and you can enjoy a first class wet, slick looking paint job. Take care.

# PROPELLER BULLETIN

12

**Sensenich Corp.**



**Lancaster, Pa. 17604**

P.O. BOX 1168

(717) 569-0435

JANUARY 1980

IT HAS COME TO OUR ATTENTION THAT SENSENICH FIXED-PITCH METAL PROPELLERS ARE SOMETIMES MODIFIED BEYOND THE LIMITS IMPOSED BY THE RESPECTIVE PROPELLER TYPE CERTIFICATE DATA SHEETS. SUCH MODIFICATION IS OFTEN MADE WHERE PROPELLERS ARE INSTALLED ON EXPERIMENTAL AIRCRAFT.

THIS PRACTICE CAN BE DANGEROUS AND IS NOT APPROVED BY SENSENICH CORPORATION. A PROPELLER IS CONSIDERED BY SENSENICH TO BE UNAIRWORTHY AFTER IT HAS BEEN REWORKED BEYOND THE LIMITS OF THE APPLICABLE TYPE CERTIFICATE DATA SHEET AND/OR THE LIMITS PUBLISHED IN THE SENSENICH METAL PROPELLER REPAIR MANUAL.

The above letter was recently received from Sensenich Corporation.



## MODEL

T.C.	S/N	P.C. No.1
------	-----	-----------

3/8-24UNF-3A	Attaching Bolts	
Torque bolts evenly	280 to 300 in.-lbs.	
equals	23 to 25 ft.-lbs.	
equals	32 to 34 N.-m.	

Threads must be clean and lubricant-free  
Wipe blades monthly with lightly oiled cloth.  
Round out and smooth nicks & gouges.

**SENSENICH CORPORATION**  
LANCASTER, PENNSYLVANIA, U.S.A.

At the left is a decal which gives the Torque values for Sensenich Props using 3/8" Diameter props. These decals are available from Sensenich, as per information on the next page.

# PROPELLER BULLETIN

Sensenich Corp.

P.O. Box 1168



Lancaster, Pa. 17604

January 15, 1980

SERVICE LETTER NO. 80-1

TO: FAA APPROVED PROPELLER REPAIR STATIONS, SENSENICH CORPORATION DISTRIBUTORS  
SUBJECT: METAL PROPELLER INSTALLATION, ATTACHING BOLT WRENCH TORQUE

## DISCUSSION:

During recent months, several instances of attaching bolt failure have been reported. Investigation has shown that these bolts had been stretched and broken by application of wrench-torque greatly exceeding the recommendations published by Sensenich Corporation.

There are several ways in which this could have happened.

For example:

- (1) The wrench-torques recommended by Sensenich have traditionally been given in units of inch-pounds. It is possible that the torque may have been applied in foot-pounds without converting the torque units (1 ft-lb = 12 inch-pounds).
- (2) The threads of the bolts may have been oiled, which decreases the friction force produced during the torquing operation and therefore increases the amount of pre-load in the bolt at a certain wrench torque.

## RECOMMENDED ACTION:

When installing a metal propeller, be certain that the threads of the bolt and of the bushings or nuts, are clean and dry (free of any lubricant). Always be certain that the wrench-torque applied is correct for the bolt being installed and in the proper units.

Blank information decals can now be ordered from Sensenich Corporation for propellers using 3/8" dia. or 1/2" dia. attaching bolts. It is recommended that propeller information decals be applied to the inboard blade section (approx. 6-1/2" from hub center) after repair of any Sensenich Fixed-Pitch Metal Propeller.

These decals are available in packages of at least 20 decals at 60¢ each, F.O.B., Lancaster, Pa., (price subject to change without notice). Please specify 3/8" and/or 1/2" dia. attaching bolts when ordering. Enclosed is a sample of the identification decal for a propeller using 3/8" attaching bolts.

### NEW ACRODUSTER ONE FLYS

Five years ago I had an up and coming young female aerobatic pilot fly my new Acroduster I in competition for the season. She did well with it, and brought the airplane some favorable attention.

Recently this same pilot, now flying for western airlines, took delivery on her very own Acroduster I.

The pilot is Cindy Rucker. The airplane is shown on our front cover.

Cindy is very pleased with her new machine, and is looking forward to the coming season. She plans on competing for at least half the season in the intermediate category before moving up to advanced. It has been almost five years since she has done any aerobatic flying to speak of.

We here at STARDUSTER will be following her progress with interest. We wish her a string of very successful seasons.

### PRICE INCREASES

Since the first of January of this year, prices have risen faster than we have ever seen them rise. You may find that your order will cost you more than you had anticipated. We are sorry. Prices are going up so fast we have a hard time staying with them.

There have been substantial increases in steel, aluminum, and wood. Parachutes have gone up to \$560.00 for a basic low speed seat pack, plus \$15.00 for the carrying case. Propellers for IO-540 engines have increased by \$100.00, although propellers for the IO-360 are still the same price.

One dandy little item that has held the line has been Gel Cel batteries. They are still the same \$52.95 plus \$3.00 packing. If you need one, don't delay ordering one. It is unlikely that they will stay the same price indefinitely.

Instruments have taken a jump in price. So has valves, much hardware, and many fittings.

Because of the general jump in prices, but mostly because of the large aluminum increases, the ACRODUSTER I now costs \$7800.00. And it is a bargain at that price.

On the next page are the current prices of steel. We hope they will hold for quite a while. And I know you hope so too.

AIRFRAME TUBING - CERTIFIED 4130 CHROME MOLY, NORMALIZED CONDITION MIL-T6736

OD"	.028	.035	.049	.058	.065	.083	.095	.109	.120	.156	.188	.219	.250
1/4"	1.30	1.30	1.44	*									
5/16	1.30	1.30	1.44	1.54	1.64	*							
3/8	*	1.30	1.45	1.55	1.64	1.81	1.90	*	1.98	*			
7/16	*	1.31	1.45	1.55	1.65	1.82	1.90	*	1.99	*			
1/2	1.31	1.31	1.46	1.56	1.67	1.83	1.91	*	2.00	*			
9/16	*	1.41	1.61	1.85	2.04	2.05	2.29	*	2.48	*	3.49	*	
5/8	*	1.41	1.61	1.85	2.05	2.06	2.30	*	2.49	*	*	*	
11/16	*	1.51	*	*	2.34	*	*	*	*	*	*	*	
3/4	*	1.51	1.95	2.15	2.35	2.49	2.62	*	2.89	3.36	3.67	4.58	5.59
7/8	*	1.61	2.11	2.16	2.55	2.87	3.04	*	3.32	3.97	4.36	4.79	9.88
1	*	1.76	2.26	2.61	2.90	3.17	3.46	*	3.71	4.54	4.94	*	6.22
1 1/8	*	1.91	2.36	2.71	2.90	3.42	3.83	*	4.15	4.94	5.64	*	6.58
1 1/4	*	2.06	2.61	2.91	3.17	3.65	4.16	*	4.42	5.29	6.09	*	7.58
1 3/8	*	2.79	2.81	3.12	3.41	3.90	4.36	*	4.68	5.74	6.62	*	7.86
1 1/2	*	2.93	2.96	4.51	3.71	4.17	4.55	4.62	5.01	6.18	7.15	*	8.49
1 5/8	*	3.13	3.16	3.60	4.00	4.45	4.84	*	5.39	6.63	7.68	*	9.71
1 3/4	*	4.46	4.26	4.29	4.31	4.74	5.22	*	5.98	7.07	8.21	*	*
1 7/8	*	4.72	4.51	4.55	4.60	5.02	5.58	*	6.18	7.56	8.91	*	*
2	*	*	4.69	4.70	4.76	*	5.86	*	6.45	*	*	*	*
2 1/8	*	*	*	5.04	*	*	*	*	*	*	*	*	*

Price Effective: Jan. 23, 1980

Price change due to increase in mill cost of steel.  
New price reflect our normal mark up formula.

Prices Subject To Change Without Notice

Please order tubes in 6" increment.

10% discount on orders of 100 feet or more of round 4130 tubing.  
Sizes may be assorted.

3-5 lbs of short lengths of 4130 tubing will be given free for welding practice, with tubing order of more than \$25.00 on request. No size selection will be made.

SMALL ORDERS CAN BE SHIPPED UPS IF TUBING CAN BE CUT INTO LENGTH 7' OR SHORTER - PLEASE ADVISE IF THIS CAN BE DONE, WHEN PLACING ORDER.

**STOLP STARDUSTER CORP.**

4301 TWINING FLABOB AIRPORT  
RIVERSIDE, CALIFORNIA 92509

714-686-7943

**STREAMLINE TUBING**



Size	Eq. Rd.	.035	.049
1.012 x .428	3/4	\$4.15	\$4.86
1.180 x .571	7/8	4.43	*
1.349 x .571	1	4.75	6.04
1.685 x .714	1 3/4	6.67	6.96
2.023 x .857	1 1/2	8.40	8.81
2.360 x 1.00	1 3/4	*	10.55
2.697 x 1.143	2	*	12.12
3.372 x 1.429	2 1/2	*	16.51

**FIREWALL MATERIAL**

	Thickness	Width	Per Linial Ft.
Stainless	.016	36"	\$8.05
Galv. Iron	.26 ga.	36"	\$2.78

Sold in required length, full sheet width only

4130 MIL-S-6758A-3  
Norm. Rod

Per Ft.	
3/16	\$ .32
1/4	.43
5/16	.71
3/8	.87
7/16	1.03
1/2	1.11
5/8	2.02
3/4	2.50
7/8	3.00

**SQUARE TUBING**



	.035	.049	.058	.065	.095	.120
3/8 x 3/8	\$2.20	\$2.35	*	*	*	*
1/2 x 1/2	2.20	2.44	*	*	*	*
5/8 x 5/8	2.33	2.65	3.00	3.45	*	*
3/4 x 3/4	2.45	3.16	3.54	3.81	*	*
7/8 x 7/8	2.62	3.43	3.80	4.53	*	*
1 x 1	2.86	3.69	4.24	4.73	5.54	6.57
	3.51	*	*	*	*	*

**RECTANGULAR TUBING**

1/4 x 3/8	*	2.69	*	*	*	*
3/4 x 1 1/2	*	3.83	*	*	*	*
7/8 x 1 1/4	*	*	*	*	6.29	*

please order tubes in 6" increment.

**WELDING ROD**  
 Oxweld #7 \$1.75/lb.  
 Mild Steel  
 Copper Coated  
 Type recommended in Manual 18 for non-heat treated assemblies.

**4130 CHROME MOLY SHEET: CONDITION N MIL-S-18729**



Size	.025	.032	.036	.040	.050	.063	.071	.080	.090	.100	.125	.160	.190	.250
1 x 36	\$1.28	1.32	1.37	1.39	1.60	1.89	2.00	2.03	2.11	2.72	3.22	4.00	5.00	6.88
2 x 36	2.33	2.42	2.50	2.55	2.97	3.50	3.77	3.83	3.89	4.55	5.77	7.31	8.69	11.43
3 x 36	3.50	3.63	3.75	3.83	4.46	5.25	5.66	5.75	5.83	6.83	8.58	10.98	13.04	17.15
9 x 9	2.62	2.78	2.97	3.09	3.36	3.83	4.13	4.55	4.66	5.05	6.22	8.49	9.46	12.38
9 x 18	4.16	4.55	4.72	5.17	5.72	6.64	7.27	8.01	8.27	9.10	11.34	14.99	17.32	22.87
18 x 18	7.55	8.17	8.57	9.41	10.32	11.99	13.15	14.49	14.87	16.52	20.56	27.20	31.30	41.47
18 x 36	14.32	15.26	16.20	17.78	19.65	22.87	25.14	27.66	28.58	31.47	39.07	52.17	59.39	78.26
24 x 36	*	19.61	20.87	22.97	25.45	29.75	32.78	*	37.37	*	51.36	*	78.44	116.55
36 x 36	27.53	*	*	*	*	*	49.17	54.17	*	61.83	*	102.12	117.66	*



PIREPS PAGE

Dear Jim,

Enclosed is the six bucks for another years subscription. I continue to enjoy the magazine. The current article about hand propping an un-attended airplane was great, and this point can never be overemphasized. Along the line of safety, I was pleased to see Poberezny's editorial in the January issue of Sport Aviation which included a letter from Tony Bingelis regarding the folly of modifying airplane designs. Heaven knows I would never do a thing like that--- Seriously, I do agree with Bingelis.

With regard to your energy editorial, you are a good airplane designer, but a hip-shot economist. The fact that our government has embraced some of your proposals only emphasizes that politicians know which way the wind blows, and, oftentimes, not much else.

To be specific, you start out with the very first point being a classical example of, "what the government should do for me." You know perfectly well that the government never does anything as well as private initiative, and it is no different in the case of energy. If alcohol made any sense, private industry would be in there with both feet. The fact that one large company (Archer Midland Daniels) is already doing it is true only because of a government subsidy. (Tax forgiveness.) Back to the first point again, we are all critical of what government does for others, but it is all too easy to put the hand out when something affects us. Where does it say that the government should guarantee us cheap fuel? And this applies to both cars and airplanes.

The facts regarding alcohol are as follows. Alcohol is energy negative. It takes 2-3 times as much energy to produce alcohol as is derived from it, and most of that energy input is now derived from oil, (farming, including tractor fuel, and fertilizer, transportation, and distillation, which itself uses 150% energy.) The current processes for distilling alcohol use primarily gas and oil, both of which are imported. Coal would at least be a domestic source, but it is still energy negative, and would be much better used by extracting the liquid fuel directly from the coal.

Actually, all this is irrelevant. In order to achieve your goal of converting every gallon of gasoline to gasohal, it would require 150% of our current corn production. According to the September issue of FORTUNE magazine, a 1 % increase in corn consumption would lead to a 2 % increase in price.

Put your pencil to some simple arithmetic, and you will come up with some surprising figures. If a midwesterner now buys a gallon of gasohal for a 5 cent premium over gasoline, it means that he is paying a 50 cent premium per gallon of alcohol, since he only bought 1/10 of a gallon. By the same token, a 5 cent per gallon tax forgiveness represents a 50 cents per gallon subsidy. Now we are talking about the real cost of alcohol, and it is \$2.00 per gallon. And in light of the last paragraph, this is just the start. Burning corn for motive power is not the answer, and you can paste that in your hat.

On your third point, which is to decontrol oil, I heartily agree. With regard to the subsidy, forget it. Subsidies only provide another foot in the door by government.

The western United States, with its giant underground fields of coal, shale oil, and uranium, is generally regarded as having more energy than all the OPEC nations ever had. The energy is here, but nobody said it was going to be cheap, and that is a point that we had better learn to accept.

Come to think of it, your economics isn't so bad after all. In the last paragraph you said that inflation will continue..... Prices will rise. I couldn't agree with you more.

Fraternally,

Dean Hall

.....

Editors Note: Except when he is disagreeing with various opinions of mine, Dean Hall is a fine fellow. And, usually, he is a good friend.

Going back to the very first point, I see nothing wrong in expecting to government to do things for the citizens. In fact, I thought that was the sole purpose of a government. If it doesn't serve the citizens it has no reason for existence.

Deans point about alcohol being energy expensive is well taken. But is it not better to pay more and keep the money in this country, in a non-inflationary cycle than send the money to Iran, and then have inflation to keep down the buying power of our permanently exported money?

Alcohol is a viable short term fuel as I see it. It can come from any vegetation, not just corn. Although turning corn into alcohol would be a good way to use up the surplus that was not shipped to Russia. I don't believe the farmers would complain if the price of grain thereby rose a little.

Any fuel can be used to make alcohol. Coal, wood, natural gas, solar energy, water power, even other grain. Fuels can be used that are totally incompatible with motive power useage, and alcohol can be produced and used with a minimum of technology. This is what makes it desirable, in my opinion for a short term useage, provided our national goal is to break our dependence on foreign oil.

Brazil is fueling a large portion of its vehicles on pure alcohol, not just gasohol. And Brazil plans to fuel all its vehicles with alcohol. Its new cars are coming off the production lines equipped to burn pure alcohol. The fuel is being made from sugar cane, which is a much more efficient energy producer than corn and other grains.

Agreed, the best way to generate new fuel is by making synthetic fuels from coal and shale. But that is five years down the road. And we need substitute fuels as quickly as possible.

I wish to thank Dean for his thoughtful, well written letter. And giving careful consideration to his points, I feel he may be right. Maybe alcohol is not a viable short term fuel.

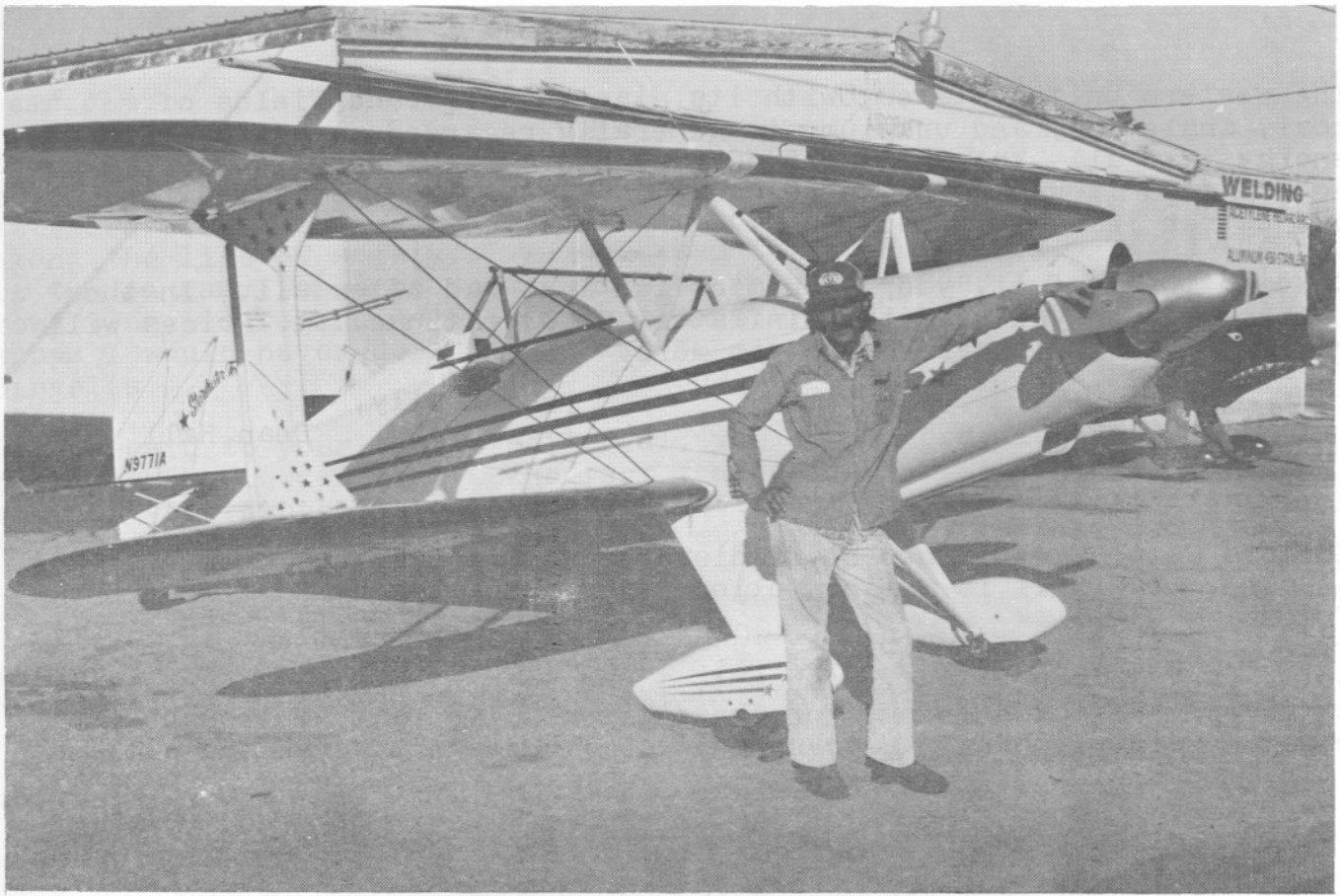

TOM ABERLE AND THE STARDUSTER TOO HE RECENTLY FINISHED BUILDING



GARY DEBAUN AND HIS NEW SMITH MINIPLANE. BASED AT CORONA, CA., GARY IS PUTTING A LOT OF HOURS ON HIS NEW PLANE, IN A SHORT TIME.

# Lane Metal Products Company, Inc.

20

BOX 388  
KING OF PRUSSIA, PA 19406

PHONE: 272-4531  
AREA CODE 215

Dear Jim,

Thanks so much for the service on my inverted tank. Got it in a few hours before our bad weather started. Works fine. Sending picture of my Duster "EAGLESTAR". Some of your fellows may remember it from Oshkosh 79 when Frank Christian gave me such a hard time about my paint design, and I had to move it from the main area. Its a great feeling to fly 800 miles and get out of your pride and joy and have a guy threaten you with a lawsuit. Oh well: Sending UPS, as well as fee for STARDUSTER MAGAZINE.

Some Info on "EAGLESTAR TOO". I have 0-360 A4A, with a 35 MM Lakes Injector with 5 pound engine fuel regulated to 1.5 pounds at the Injector. Also have Acroline inverted oil. You can guess why I didn't use a Christian unit. Also I have a lexan floor under pilots seat. The cover is ceconite with Imrom. She wieghs in at 100 pounds and I get approximately 128 cruise at 2450 RPM and a 76-60 fixed prop. It uses 7.4 GPH cross country and 9 GPH doing aerobatics.

My winter project is to make a little wheel pant for the tail wheel just to say I did it. Well, thanks again, and hope to see you folks at Oshkosh 80.

Yours,



DICK GONZALES



EAGLESTAR TOO ON THE LEFT. LOOKS LIKE A VERY NICE PAINT SCHEME.



OUR OLD FRIEND, GENE BURNETT, OF 2022 KASOLD DRIVE, LAWRENCE, KANS, 66044, SENDS US THE TWO PICTURES ON THIS PAGE OF HIS TWO AIRPLANES. HIS STARDUSTER TOO FIRST FLEW JULY 26, 1977. HAS FLOWN PERFECT SINCE FIRST FLIGHT. NOW HAS 55 HOURS ON IT. GENS BONANZA HAS ALL THE GOODIES YOU CAN BUY, AND HAS A CUSTOM PAINT JOB, DESIGNED BY GENE TO MATCH HIS STARDUSTER TOO. SAME COLORS EXACTLY.



GARY DEBAUN AND GARY IS PUTTING A COPIER COPY OF HIS NEW PLANE

WILDFLOWER REALTY  
20115 HIGHWAY 18  
P. O. BOX 1481  
APPLE VALLEY, CA. 92307  
714-242-3681

Mr. Osborne

I'm writing you this letter because I have drawn this STAR BLAZER 1. I hope you like, you never know it could be turned in to some plans. ( with a little improvements.) So hows everthing at STOLP STARDUSTER Inc.? I have now flown my fathers STAR DUSTER TOO 3 times and I'm going stronger than ever! It's the greatest! Well, I have to go now, see you later!

Sincerly your friend,

Sean Watkins

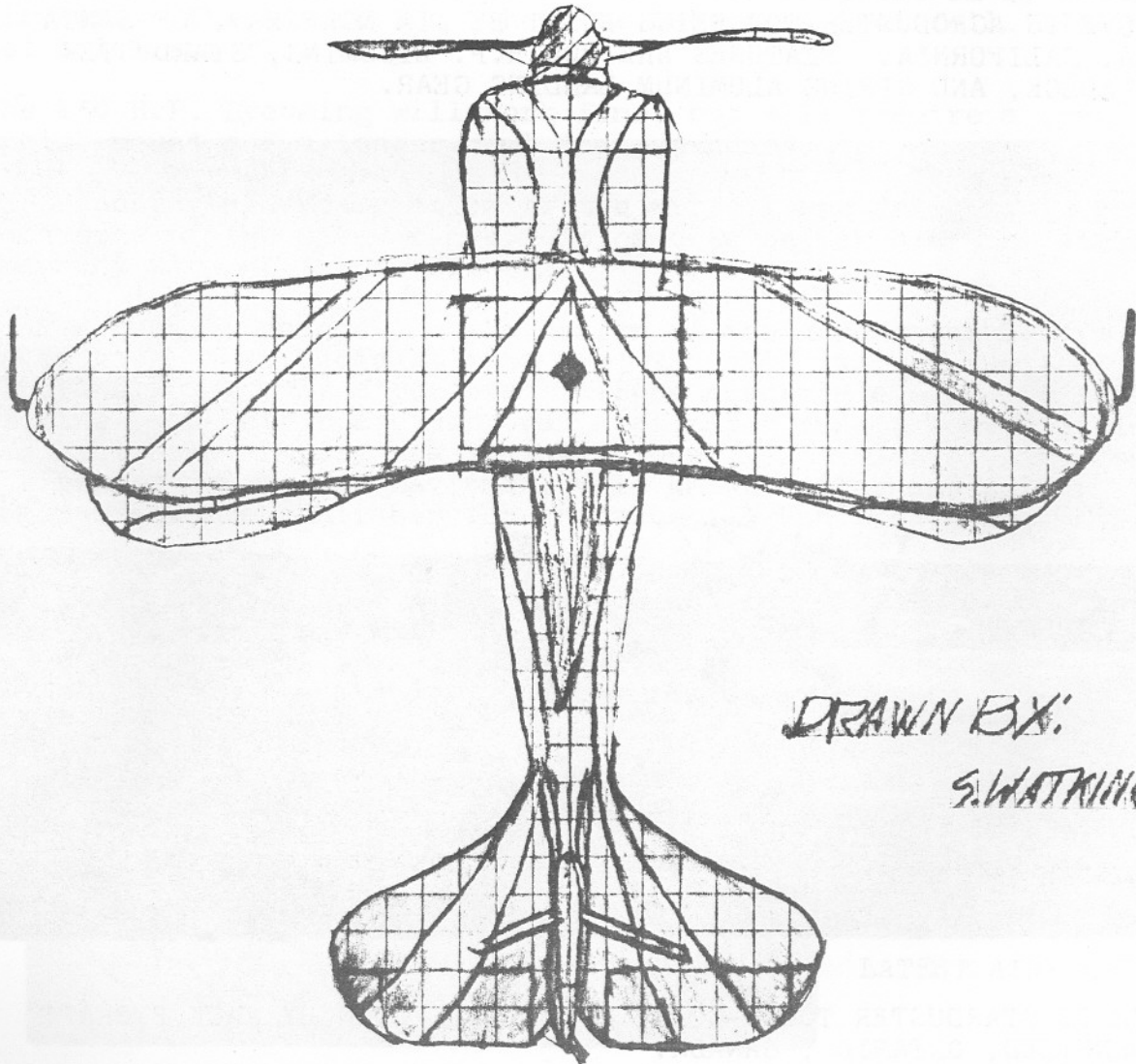
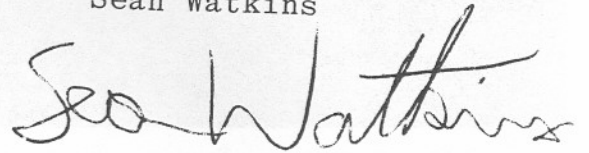

DRAWN BY:  
S. WATKINS

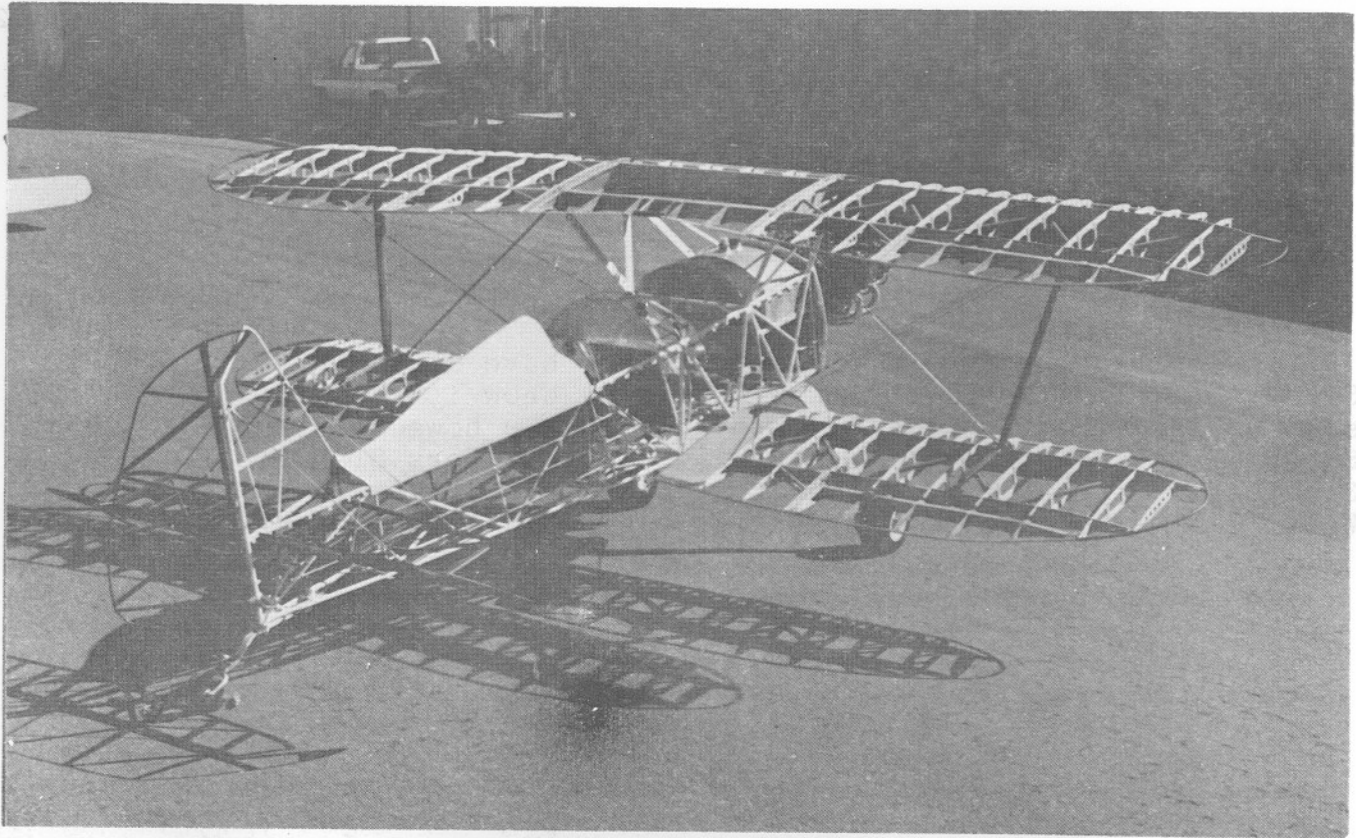

ABOVE IS ACRODUSTER TOO BEING BUILT BY JIM MCKEEHAN, OF SANTA PAULA, CALIFORNIA. FEATURES ARE 200 H.P. LYCOMING, STARDUSTER TURTLEDECK, AND SPRING ALUMINUM LANDING GEAR.

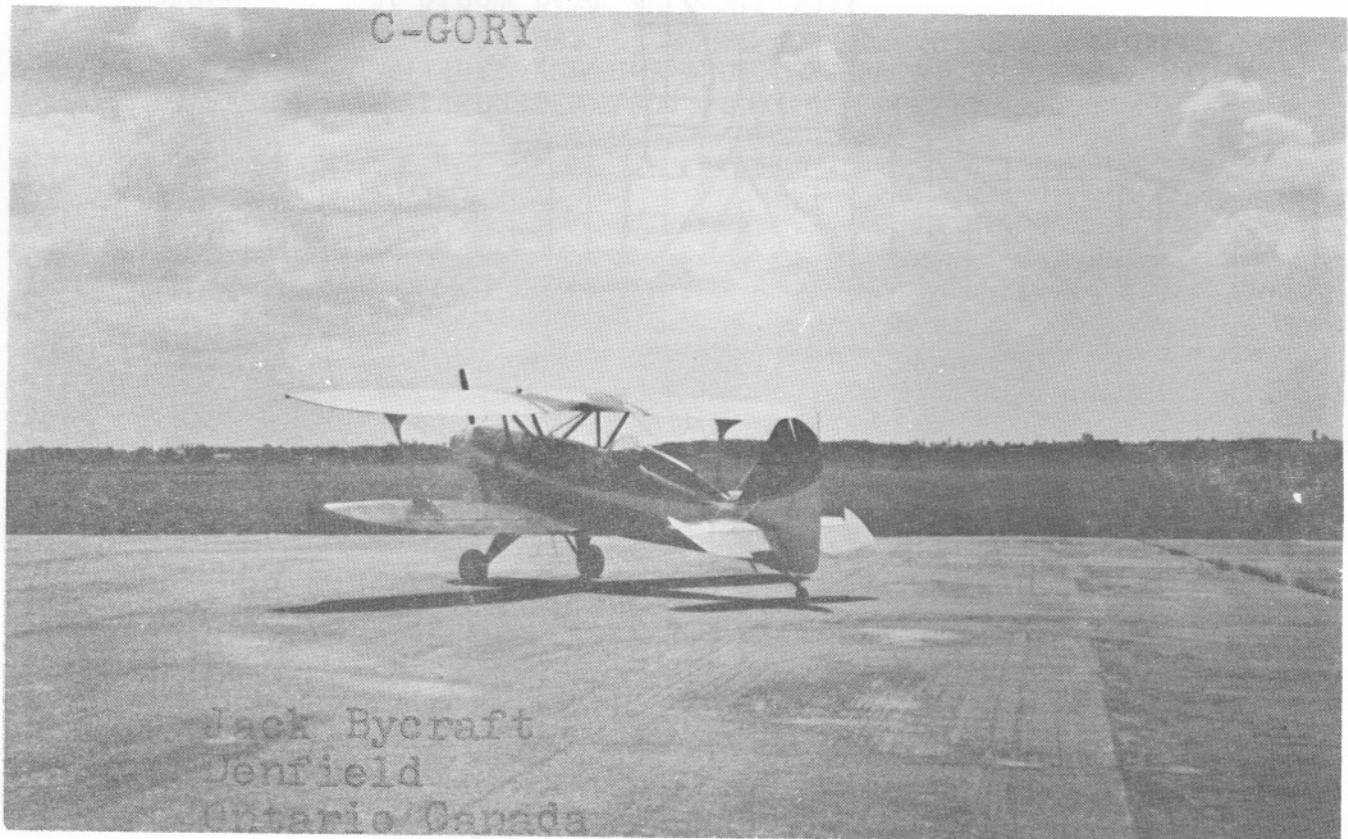

ABOVE IS STARDUSTER TOO C-GORY, BUILT AND FLOWN BY JACK BYCRAFT OF DENFIELD, ONTARIO , CANADA.

Dear Sir,

I am requesting your INFO packet on the ACRODUSTER 1. I have some questions on the aircraft. If these are not answered in the INFO packet, I would appreciate the additional information.

Does the ACRODUSTER I have the OSBORNE A-1 airfoil, or the A-2? Is it a laminar flow wing? Will 150 H.P. Lycoming work with the motor mount and/or cowling you supply in the kit? I am trying to get information on how the airfoil handles, especially at the low end of the speed spectrum. I have read that you redesigned the aircraft and strengthened the tail after an accident. If you have copies of magazine articles (Pilot reports), or can tell me what magazines have Pilot reports, I would appreciate it. I will pay for them if there is a fee. Just bill me in the return letter.

Respectfully,

DAVID GREEN  
85 Kevin Street  
Euless, Texas  
76039

.....

EDITORS REPLY: Thank you, David, for your interest in my favorite airplane. The ACRODUSTER I has the Osborne A-1 Airfoil. It is not a laminar flow wing.

The 150 H.P. Lycoming will work fine, but will require a special engine mount and a longer cowl than standard.

The handling characteristics of the airfoil are delightful, at both ends of the speed range. It handles better near the stall than any airplane I know of.

I have made no changes in the design of the Acroduster I. It has never been in an accident that the NTSB said was the fault of the airplane. The only structural failure occurred around 100 MPH over redline. The other accident was stall/spin due to poor piloting. The best Pilot report was in the October 1975 issue of Air Progress. The report was by Bud Davisson, well known writer and pilot. You might write the publisher for an issue. I don't have one.



CAL PARKER, WELL KNOWN DESIGNER OF THE TEENIE TWO FLIES OVER ARIZONA IN HIS LATEST AIRPLANE



Americo J. Mazziotti  
84 Sherwood St.  
Portland, Maine 04103

Dear Jim,

I was looking thru my album, and came across an extra picture of the model of the SA 300, with my two nieces in it, that I built.

I also remember that you had some kind of an accident concerning all the photos you had had got lost in the mails, and requesting if anybody out here in STARDUSTER land had any extra photos, to please send them to you.

Well, enclosed is the photo. Maybe you can use it in the magazine.

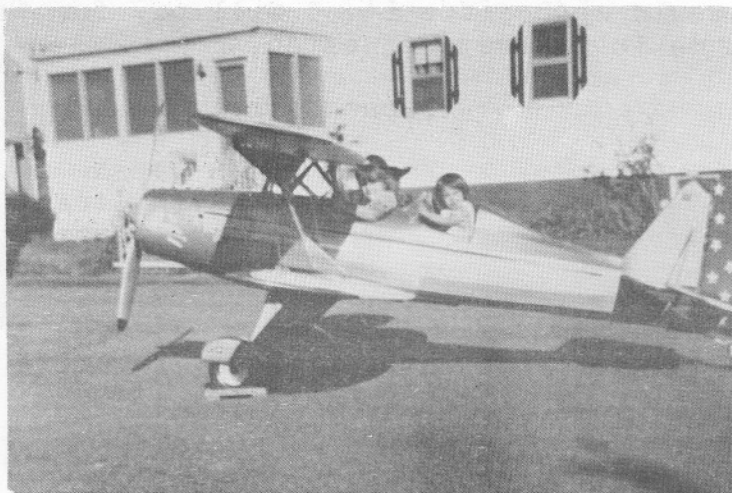

Sincerely, MAZ

PHOTO SHOWS NIECE ERICA  
IN FRONT AND NIECE DEANA  
IN REAR. THANKS FOR THE  
PHOTO. IT IS A VERY REAL  
LOOKING MODEL

Dear Hanako San,

Thank you very much for taking a chance on me and reopening my obsolete charge account.

Just received the beautiful gas tank for my STARDUSTER TOO. Enclosed, please find my check for \$200.00. It should be enough to pay off the gas tank, plus take care of the majority of the bill on the clecos I ordered

Jim, Thank you for your answers to my letter concerning my rudder horn. Between your letter and studying your Starduster under construction in your hangar, my mind was put at rest. I will make no modifications.

Your magazine is invaluable. Please keep up the excellent work.

Sincerely,

DAN COLLIER

TEMPORARY ADDRESS: 939 CAMBRIDGE AVE, SUNNYVALE, CALIF., 94087

(For Photo of Dan and his project, see top of next page.)



PICTURE OF DAN COLLIER  
AND HIS STARDUSTER TOO  
PROJECT. LOOKS LIKE DAN  
IS WELL ALONG ON HIS FIRST  
90 PER CENT.



ABOVE PICTURE SHOWS GAIL (PINK BARONESS) TURNER, AND HER ORANGE,  
YELLOW, AND RED MARQUARDT CHARGER. THE HANDSOME YOUNG MAN WITH  
HER IS HER SON, WILLIE. THE PAINT JOB LOOKS LIKE SHE HAS BEEN  
HANGING AROUND "STARDUSTER" TOO LONG.

THANKS FOR THE PICTURE, GAIL.

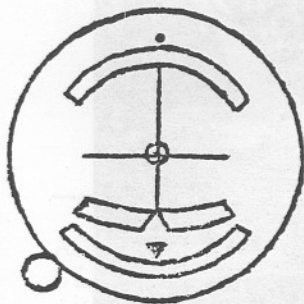

# ACES\*

## AVIATORS COORDINATED EDUCATION SYSTEM

Each year seems to bring more activities my way and 1979 has been full of new adventures.

The engine shop at Flying Tigers is busier than ever and our efforts to completely overhaul the angle and main gearboxes on the 747 engines have paid off. A co-worker and myself spent most of the year setting up the procedures for this operation.

In April and October I was a participant at conferences on Aerospace Education. As a member of the "Women in Aerospace" panels, I had an excellent opportunity to spread the word about the shortage of aviation maintenance technicians. I hope through my efforts more high school students, especially girls, will consider careers in the field of maintenance pertaining to the aviation and space industry.

Progress on my biplane has surged ahead so that I am now at the point where I am planning to cover the airframe. My next step is to find an engine and prop and go flying.

During July I obtained an IFR simulator and I am now preparing for the grand opening of my instrument training ground school. I am looking forward to helping pilots upgrade their flying skills.

The photo Christmas card this year shows the cockpit of a new 747-200 freighter. This seems like a nice place to be, but I prefer the fun and freedom of general aviation flying.

MERRY CHRISTMAS & HAPPY NEW YEAR

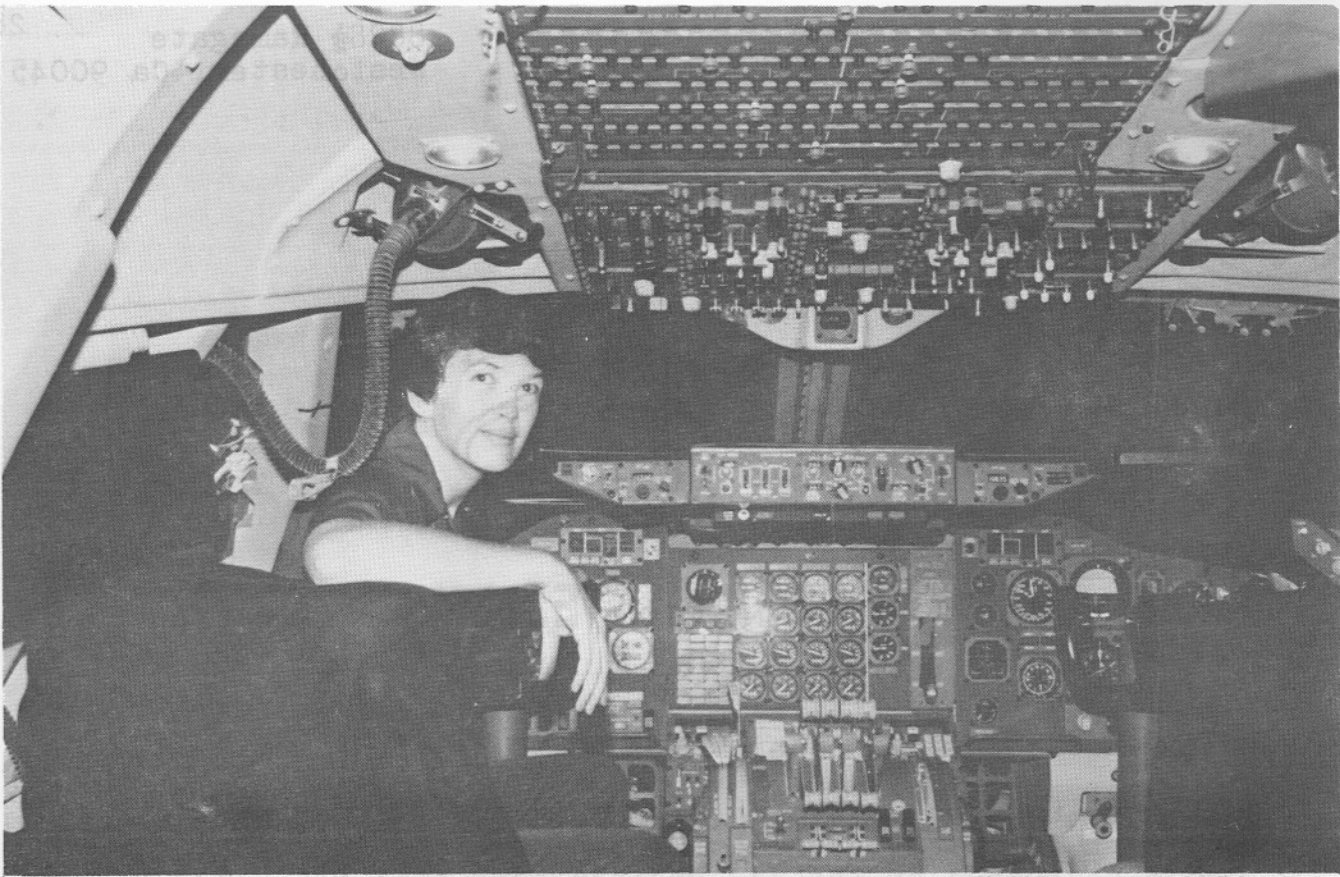

FLYING TIGER MECHANIC AND ACRODUSTER TOO BUILDER, DIANE "ACE" ABRAMSON, SITS IN THE COCKPIT OF A 747 SHE WORKS ON.



A BEAUTIFUL STARDUSTER TOO SEEN AT THE RAMONA FLYIN-----

# Classified Ads

ADVERTISING CLOSING DATE:-JANUARY 1; APRIL 1, JULY 1, OCTOBER 1.  
CLASSIFIED ADVERTISING RATE: \$4.00 PER COLUMN INCH- MINIMUM CHARGE,  
\$4.00. MAKE CHECKS PAYABLE TO STOLP STARDUSTER CORPORATION.

## FOR SALE

NEW WINGS--FOR  
STARDUSTER TOO"S  
23012 AIRFOIL---  
BETTER PERFOR-  
MANCE INVERTED.  
FASTER AND LIGH-  
TER AILERONS.  
AVAILABLE READY  
BUILT ONLY---  
FROM STOLP  
STARDUSTER CORP.  
\$4900.00 READY  
TO COVER.

NASA INLET DUCTS.  
SIZED FOR 360-  
540 CUBIC INCH  
ENGINES. MADE OF  
FIBERGLASS.  
READY TO INSTALL.  
GIVES UP TO ONE  
INCH MORE M.P.  
ONLY \$50.00 FROM  
STARDUSTER CORP.

"STARDUSTER AIR-  
CRAFT" PATCHES--  
THE BEST WE HAVE  
SEEN. 3-1/2 x 4  
MAXIMUM SIZE---  
TOP HEAVY OVAL  
SHAPE. PICTURE  
OF A STARDUSTER  
TOO TYPE AIRPLANE  
FRONT VIEW, WITH  
"STARDUSTER AIR-  
CRAFT" SURROUND-  
ING PICTURE. ONLY  
\$4.95 FROM STOLP  
STARDUSTER CORP.

NEW, CUSTOM SERVICE  
AVAILABLE FOR STARDUSTER  
AIRPLANE OWNERS-----  
CUSTOM MADE BACK PATCH  
WITH A PICTURE OF YOUR  
AIRPLANE, YOUR NAME, &  
"N" NUMBER. SEND PIC-  
TURE, NAME, AND NUMBER  
TO STOLP STARDUSTER CORP.  
ONLY \$29.95 FOR TOP, SIDE  
OR FRONT VIEW. ONLY  
\$49.95 FOR QUARTERING  
VIEW--IN FULL COLOR

BUILD AND FLY THE WORLDS  
EASIEST-TO-BUILD, AND  
HOTTEST PERFORMING AERO-  
BATIC BIPLANE-- THE ACRO-  
DUSTER ONE.

BROCHURE--\$5.00  
COMPLETE KIT--\$7800.00

NEW GEL CEL BATTERY----  
MAKES OTHER BATTERIES OB-  
SOLETE. 12 V., 28 A.H.  
NO SERVICING--NOTHING TO  
SPILL. DOES NOT HAVE TO  
BE ENCLOSED IN A BATTERY  
BOX. STILL AVAILABLE FOR  
THE LOW, LOW PRICE OF ONLY  
\$52.95, PLUS \$3.00 PACK-  
ING CHARGE. FAST SERV-  
ICE--SHIPPED WITHIN 24  
HOURS FROM STOLP STAR-  
DUSTER CORP.

NEW MOUNTING RACK FOR  
GEL CEL BATTERY. MADE OF  
4130 STEEL. MAY BE BOLT-  
ED TO FIREWALL. ONLY  
\$45.00 FROM "STARDUSTER".

FOR A HAPPY ENDING----  
NEW "T" FOAM CUSHIONS.  
MADE FROM TWO DIFFERENT  
DENSITIES OF NASA DE-  
VELOPED FOAM. USED FOR  
ASTRONAUTS COUCHES AND  
WHEEL CHAIR PATIENTS.  
YOU NEVER FELT IT SO  
GOOD. \$25.00 FOR THAT  
GOOD FEELING.

PARACHUTES----PARACHUTES

THE BEST AVAILABLE-----  
SEAT PACK OR BACK PACK.  
ONLY 14 POUNDS--MADE TO  
FIT YOU. COLORS AVAIL-  
ABLE ARE RED, GOLD, BLACK,  
BLUE, AND ORANGE. ALL WITH  
BLACK TRIM.

LOW SPEED, NON-ADJUSTABLE  
SEAT OR BACK PACK-\$560.00

ADJUSTABLE-----\$570.00

STANDARD CATEGORY, NON-  
ADJUSTABLE, SEAT OR  
BACK PACK-----\$620.00

ADJUSTABLE-----\$630.00

KIT BAG, SEAT PACK-\$15.00

KIT BAG, BACK PACK-\$16.00

TEMPRA-FOAM CUSHION FOR  
SEAT PACKS-----\$25.00

DELIVERY TIME 7-14 DAYS.

STEWART WARNER OIL COOLERS  
CERTIFIED--USE TWO FOR  
200 H.P. ENGINES IN TWO  
PLACE BIPLANES. BUY AT  
OUR LOW DISCOUNT PRICE  
OF ONLY \$125.00 EACH.  
STOLP STARDUSTER CORP.

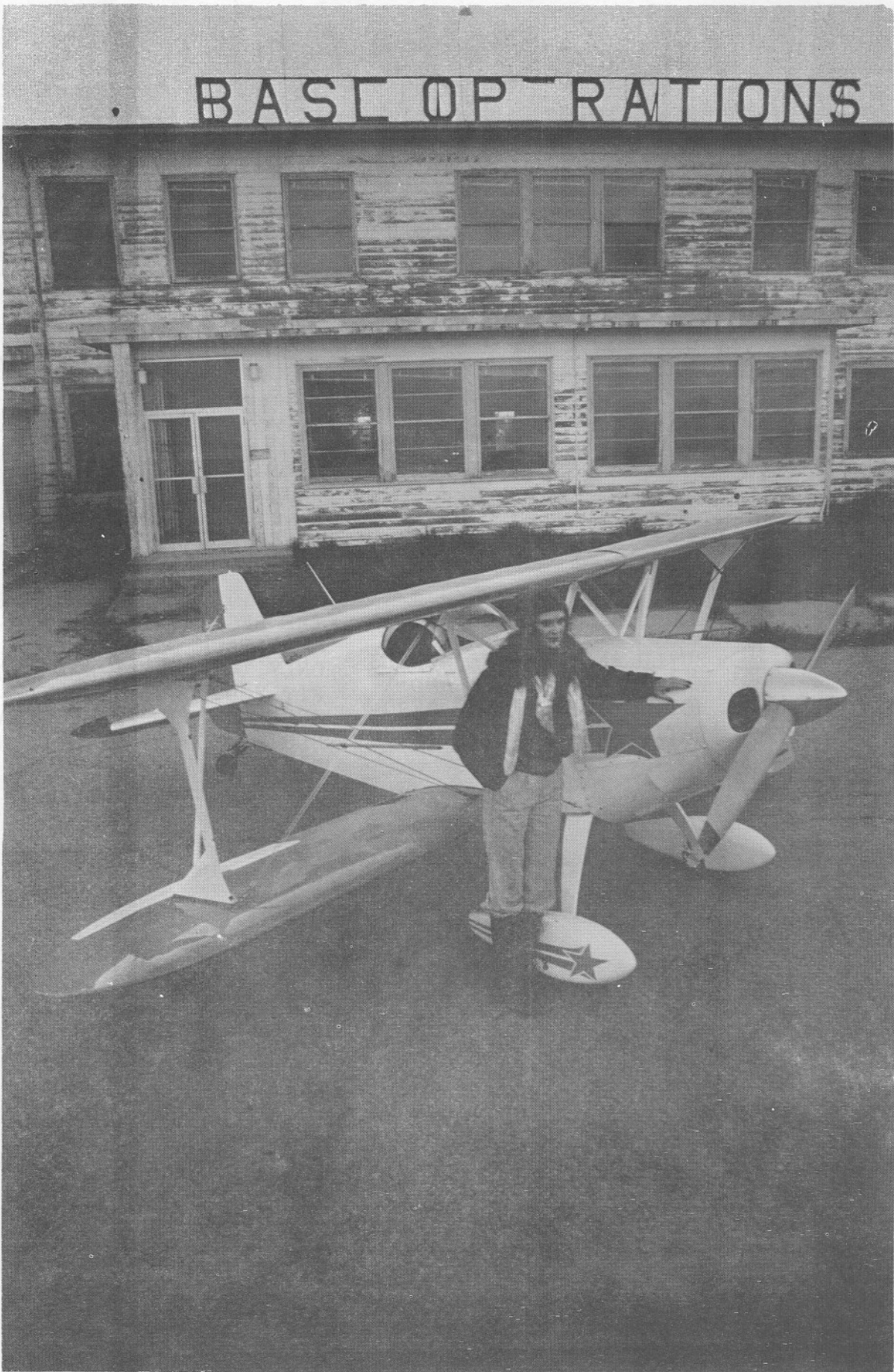

BEAUTIFUL STARBUSTER TOO SEEN AT THE SANDONA FLYIN-----